

# DATA SHEET

## **SAA5249**

**Integrated VIP and Teletext with  
Background Memory Controller  
(IVT1.1BMCX)**

Preliminary specification  
Supersedes data of December 1993  
File under Integrated Circuits, IC02

1996 Nov 07

# Integrated VIP and Teletext with Background Memory Controller (IVT1.1BMCX)

SAA5249

## FEATURES

- Complete teletext decoder featuring a background memory controller in a single 48-pin DIP package. Capable of storing of up to 512 teletext pages in an external DRAM, giving instant access to the teletext data
- Automatic processing of extension packet 26 for widest possible language decoding. All our standard language options can be available, and the language option is readable via I<sup>2</sup>C-bus.
- 100% hardware compatible with the SAA5247 plug-in replacement and with the possibility of extra market in those countries with packet 26 transmissions. Still pin-aligned to SAA5254 and SAA5244A.
- 100% software compatible with the SAA5247, and SAA5244A, except if the special OSD symbols were used. Also 100% software compatible to SAA5254. In all events there is a change to the ROM ID number.
- The device is pin-aligned with the other members of the new Philips teletext decoder family, i.e. SAA5281 and the SAA5254, making one hardware solution for the whole range
- Low software overhead for the microprocessor
- RGB interface to standard colour decoder ICs, push-pull output drive.



## GENERAL DESCRIPTION

The Integrated VIP and Teletext (IVT1.1BMCX) is a teletext decoder (contained within a single chip package) for decoding 625-line based World System Teletext transmissions. With its built-in background memory controller the device can store incoming teletext packets in the external 1M4 DRAM. With this large packet store which can be rapidly scanned, we can achieve near instantaneous access to all the pages transmitted by the broadcaster.

This version of the decoder also contains some extra hardware to process extension packet 26 automatically, extending the markets to which the TV chassis can be shipped and offering many more language options for the set maker.

## QUICK REFERENCE DATA

SYMBOL	PARAMETER	MIN.	TYP.	MAX.	UNIT
V <sub>DD</sub>	supply voltage	4.5	5.0	5.5	V
I <sub>DD</sub>	supply current	–	90	120	mA
V <sub>syn</sub>	sync amplitude	0.1	0.3	0.6	V
V <sub>vid</sub>	video amplitude	0.7	1.0	1.4	V
f <sub>X TAL</sub>	crystal frequency	–	27	–	MHz
T <sub>amb</sub>	operating ambient temperature	–20	–	+70	°C

## ORDERING INFORMATION

TYPE NUMBER	PACKAGE		
	NAME	DESCRIPTION	VERSION
SAA5249P/E	DIP48	plastic dual in-line package; 48 leads (600 mil)	SOT240-1
SAA5249GP/E	QFP64	plastic quad flat package; 64 leads (lead length 1.95 mm); body 14 × 20 × 2.7 mm; high stand-off height	SOT319-1

# Integrated VIP and Teletext with Background Memory Controller (IVT1.1BMCX)

SAA5249

## BLOCK DIAGRAM

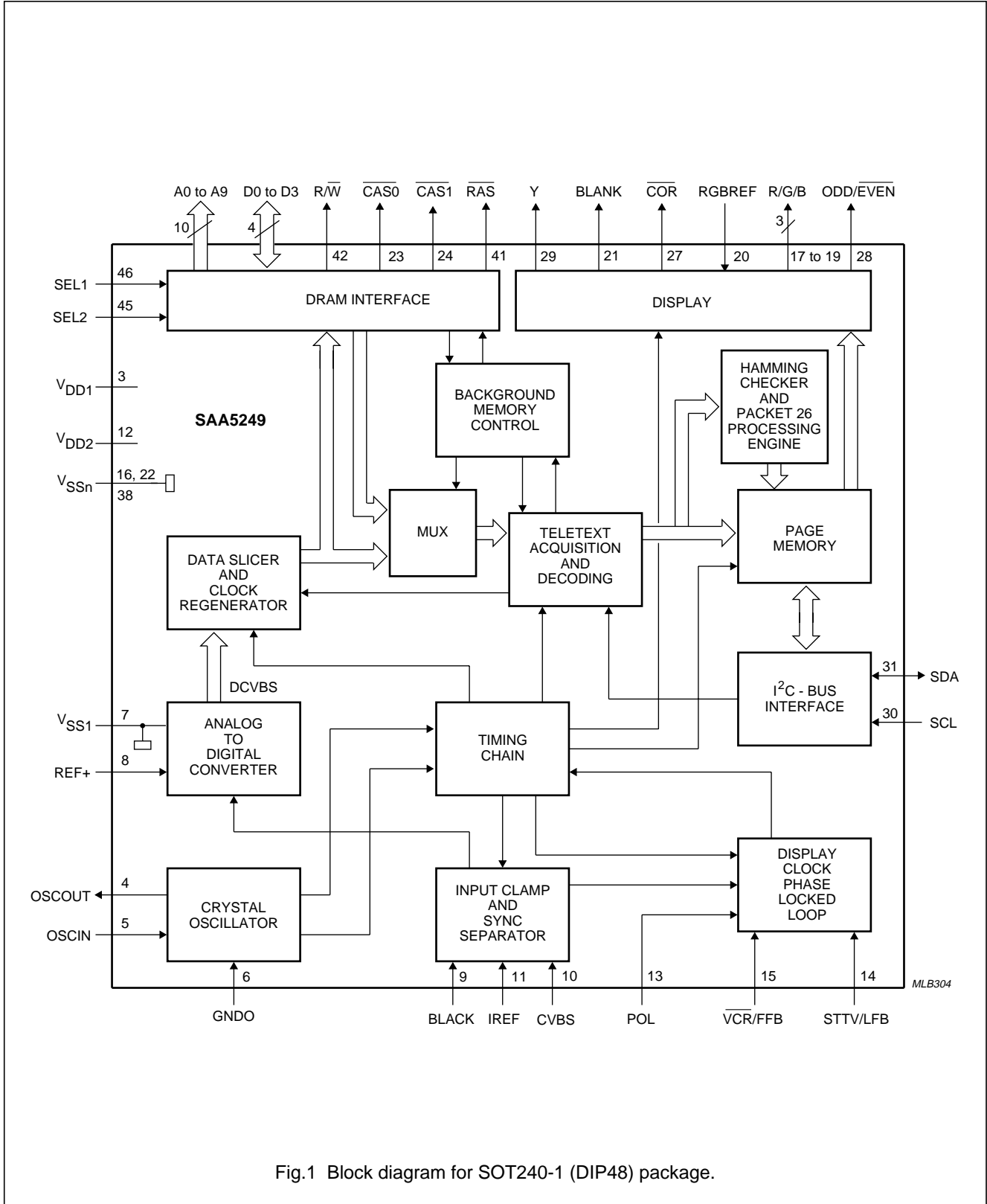

Fig.1 Block diagram for SOT240-1 (DIP48) package.

# Integrated VIP and Teletext with Background Memory Controller (IVT1.1BMCX)

SAA5249

**PINNING**

SYMBOL	PIN		DESCRIPTION
	SOT240-1	SOT319-1 <sup>(1)</sup>	
n.c.	1	1	not connected
n.c.	2	2	not connected
V <sub>DD1</sub>	3	25	+5 V supply
OSCOU	4	27	27 MHz crystal oscillator output
OSCIN	5	28	27 MHz crystal oscillator input
GNDO	6	29	0 V crystal oscillator ground
V <sub>SS1</sub>	7	12	0 V ground
REF+	8	32	positive reference voltage; this pin should be connected to ground via a 100 nF capacitor
BLACK	9	35	video black level storage pin; this pin should be connected to ground via a 100 nF capacitor
CVBS	10	36	composite video input pin; a positive-going 1 V (p-p) input is required, connected via a 100 nF capacitor
IREF	11	37	reference current input pin; connected to ground via a 27 kΩ resistor
V <sub>DD2</sub>	12	38	+5 V supply
POL	13	39	STTV/LFB/FFB polarity selection pin
STTV/LFB	14	40	sync to TV output pin/line flyback input pin; function controlled by an internal register bit (scan sync mode)
VCR/FFB	15	42	PLL time constant switch/field input pin; function controlled by an internal register bit (scan sync mode)
V <sub>SS2</sub>	16	30	0 V ground
REF-	-	31	negative reference voltage; this pin should be connected to REF+ via a 100 nF capacitor
R	17	49	dot rate character output of the RED colour information
G	18	50	dot rate character output of the GREEN colour information
B	19	51	dot rate character output of the BLUE colour information
RGBREF	20	52	input DC voltage to define the output high level on the RGB pins
BLANK	21	53	dot rate fast blanking output
V <sub>SS3</sub>	22	54, 55	0 V ground; internally connected for SOT319
CAS0	23	56	column address select to external DRAM for BMCX function
CAS1	24	57	column address select to external DRAM for BMCX function for second DRAM where two 256 k × 4 devices are used
A4	25	58	address output to external DRAM for BMCX function
A3	26	59	address output to external DRAM for BMCX function
COR	27	60	programmable output to provide contrast reduction of the TV picture for mixed text and picture displays or when viewing newsflash/subtitle pages; open drain output
ODD/EVEN	28	61	25 Hz output synchronized with the CVBS input field sync pulses to produce a non-interlaced display by adjustment of the vertical deflection currents

# Integrated VIP and Teletext with Background Memory Controller (IVT1.1BMCX)

SAA5249

SYMBOL	PIN		DESCRIPTION
	SOT240-1	SOT319-1 <sup>(1)</sup>	
Y	29	62	dot rate character output of teletext foreground colour information; open drain output
SCL	30	63	serial clock input for I <sup>2</sup> C-bus; it can still be driven HIGH during power-down of the device
SDA	31	64	serial data port for the I <sup>2</sup> C-bus; open drain output. It can still be driven HIGH during power-down of the device
A5	32	4	address output to external DRAM for BMCX function
A2	33	5	address output to external DRAM for BMCX function
A6	34	6	address output to external DRAM for BMCX function
A1	35	8	address output to external DRAM for BMCX function
A7	36	9	address output to external DRAM for BMCX function
A0	37	11	address output to external DRAM for BMCX function
V <sub>SS4</sub>	38	43	0 V ground
A8	39	13	address output to external DRAM for BMCX function
A9	40	14	address output to external DRAM for BMCX function
$\overline{\text{RAS}}$	41	15	row address select to external DRAM
$\overline{\text{R/W}}$	42	18	read/write for external DRAM
D2	43	19	data input/output for external DRAM
D0	44	20	data input/output for external DRAM
SEL2	45	21	RAM select input to choose external DRAM size
SEL1	46	22	RAM select input to choose external DRAM size
D3	47	23	data input/output for external DRAM
D1	48	24	data input/output for external DRAM

**Note**

1. The remaining pins for SOT319 are not connected.

Integrated VIP and Teletext with Background  
Memory Controller (IVT1.1BMCX)

SAA5249

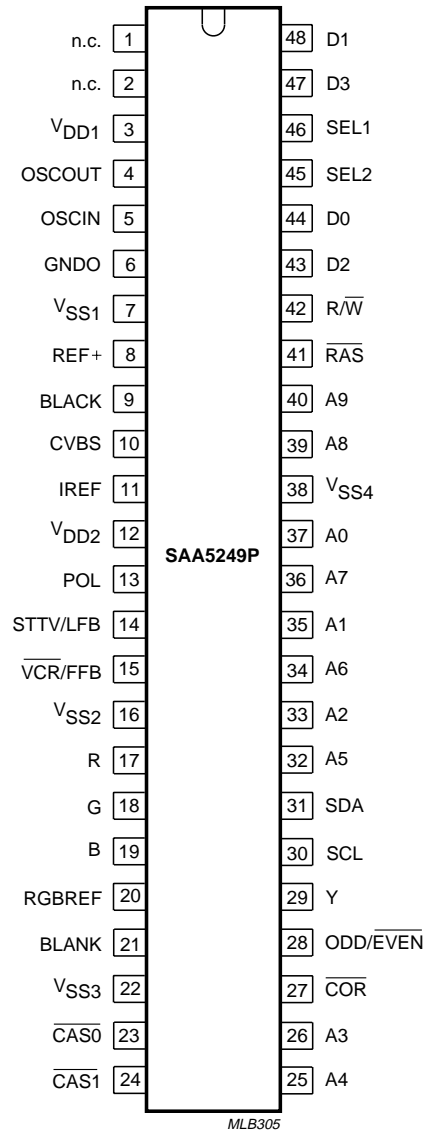

Fig.2 Pin configuration; SOT240-1 (DIP48).

Integrated VIP and Teletext with Background  
Memory Controller (IVT1.1BMCX)

SAA5249

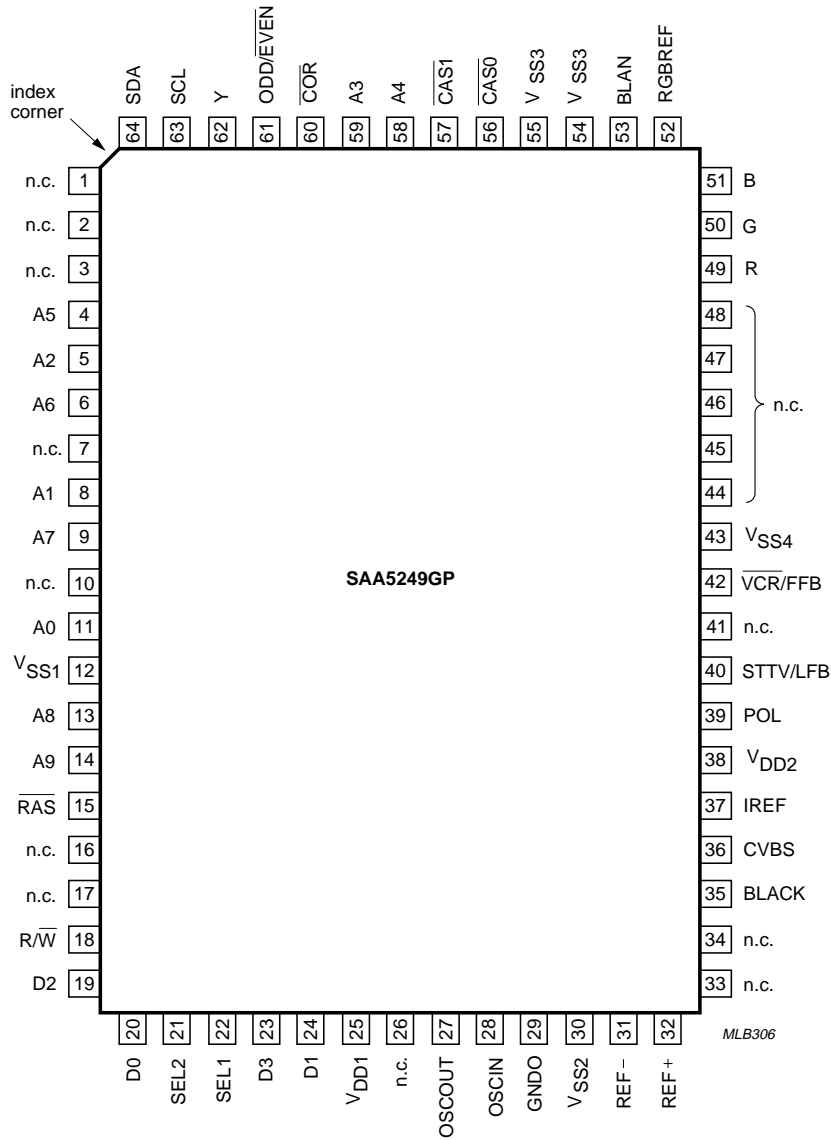

Fig.3 Pin configuration; SOT319-1 (QFP64).

---

**Integrated VIP and Teletext with Background  
Memory Controller (IVT1.1BMCX)**

---

**SAA5249****LIMITING VALUES**

In accordance with Absolute Maximum Rating System (IEC 134).

<b>SYMBOL</b>	<b>PARAMETER</b>	<b>MIN.</b>	<b>MAX.</b>	<b>UNIT</b>
$V_{DD}$	supply voltage (all supplies)	-0.3	+6.5	V
$V_I$	input voltage (any input)	-0.3	$V_{DD} + 0.5$	V
$V_O$	output voltage (any output)	-0.3	$V_{DD} + 0.5$	V
$I_O$	output current (each output)	-	$\pm 10$	mA
$I_{IOK}$	DC input or output diode current	-	$\pm 20$	mA
$T_{amb}$	operating ambient temperature	-20	+70	°C

**QUALITY AND RELIABILITY**

This device will meet Philips Semiconductors General Quality Specification for Business group "Consumer Integrated Circuits SNW-FQ-611-Part E". The principal requirements are shown in Tables 1 to 4.



# Integrated VIP and Teletext with Background Memory Controller (IVT1.1BMCX)

SAA5249

**Group A****Table 1** Acceptance tests per lot

TEST	REQUIREMENTS <sup>(1)</sup>
Mechanical	cumulative target: <100 ppm
Electrical	cumulative target: <100 ppm

**Group B****Table 2** Processability tests (by package family)

TEST	REQUIREMENTS <sup>(1)</sup>
Solderability	<7% LTPD
Mechanical	<15% LTPD
Solder heat resistance	<15% LTPD

**Group C****Table 3** Reliability tests (by process family)

TEST	CONDITIONS	REQUIREMENTS <sup>(1)</sup>
Operational life	168 hours at $T_j = 150\text{ }^\circ\text{C}$	<1500 FPM; equivalent to <100 FITS at $T_j = 70\text{ }^\circ\text{C}$
Humidity life	temperature, humidity, bias (1000 hours, 85 °C, 85% RH or equivalent test)	<2000 FPM
Temperature cycling performance	$T_{\text{stg(min)}}$ to $T_{\text{stg(max)}}$	<2000 FPM

**Table 4** Reliability tests (by device type)

TEST	CONDITIONS	REQUIREMENTS <sup>(1)</sup>
ESD and latch-up	ESD Human body model 2000 V, 100 pF, 1.5 k $\Omega$	<15% LTPD
	ESD Machine model 200 V, 100 pF, 1.5 k $\Omega$	<15% LTPD
	latch-up 100 mA, $1.5 \times V_{DD}$ (absolute maximum)	<15% LTPD

**Note to Tables 1 to 4**

- ppm = fraction of defective devices, in parts per million.  
LTPD = Lot Tolerance Percent Defective.  
FPM = fraction of devices failing at test condition, in Failures Per Million.  
FITS = Failures In Time Standard.

# Integrated VIP and Teletext with Background Memory Controller (IVT1.1BMCX)

SAA5249

**CHARACTERISTICS**

$V_{DD} = 5\text{ V} \pm 10\%$ ;  $T_{amb} = -20\text{ to }+70\text{ }^{\circ}\text{C}$ ; unless otherwise specified.

SYMBOL	PARAMETER	CONDITIONS	MIN.	TYP.	MAX.	UNIT
<b>Supplies</b>						
$V_{DD}$	supply voltage		4.5	5.0	5.5	V
$I_{DD(tot)}$	total supply current		–	90	120	mA
<b>Inputs</b>						
<b>CVBS</b>						
$V_{sync}$	sync amplitude		0.1	0.3	0.6	V
$t_{d(sync)}$	delay from CVBS to TCS output from STTV buffer (nominal video, average of leading/trailing edge)		–150	0	+150	ns
$\Delta t_{d(sync)}$	change in sync delay between all black and all white video input at nominal levels		0	–	25	ns
$V_{vid(p-p)}$	video input amplitude (peak-to-peak value)		0.7	1.0	1.4	V
	display PLL catching range		$\pm 7$	–	–	%
$Z_{source}$	source impedance		–	–	250	$\Omega$
$C_i$	input capacitance		–	–	10	pF
<b>IREF</b>						
$R_{gnd}$	resistor to ground		–	27	–	k $\Omega$
<b>POL</b>						
$V_{IL}$	LOW level input voltage		–0.3	–	+0.8	V
$V_{IH}$	HIGH level input voltage		2.0	–	$V_{DD} + 0.5$	V
$I_{LI}$	input leakage current	$V_i = 0\text{ to }V_{DD}$	–10	–	+10	$\mu\text{A}$
$C_i$	input capacitance		–	–	10	pF
<b>LFB</b>						
$V_{IL}$	LOW level input voltage		–0.3	–	+0.8	V
$V_{IH}$	HIGH level input voltage		2.0	–	$V_{DD} + 0.5$	V
$I_{LI}$	input leakage current	$V_i = 0\text{ to }V_{DD}$	–10	–	+10	$\mu\text{A}$
$I_i$	input current	note 1	–1	–	+1	mA
$t_{d(LFB)}$	delay between LFB front edge and input video line sync		–	250	–	ns
<b><math>\overline{VCR}/\text{FFB}</math></b>						
$V_{IL}$	LOW level input voltage		–0.3	–	+0.8	V
$V_{IH}$	HIGH level input voltage		2.0	–	$V_{DD} + 0.5$	V
$I_{LI}$	input leakage current	$V_i = 0\text{ to }V_{DD}$	–10	–	+10	$\mu\text{A}$
$I_i$	input current	note 1	–1	–	+1	mA

# Integrated VIP and Teletext with Background Memory Controller (IVT1.1BMCX)

SAA5249

SYMBOL	PARAMETER	CONDITIONS	MIN.	TYP.	MAX.	UNIT
RGBREF note 2						
V <sub>IL</sub>	LOW level input voltage		-0.3	-	V <sub>DD</sub> + 0.5	V
I <sub>LI</sub>	input leakage current	V <sub>i</sub> = 0 to V <sub>DD</sub>	-10	-	+10	μA
I <sub>DC</sub>	DC current		-	-	10	mA
SEL1 AND SEL2						
V <sub>IL</sub>	LOW level input voltage		-0.3	-	+0.8	V
V <sub>IH</sub>	HIGH level input voltage		2.0	-	V <sub>DD</sub> + 0.5	V
I <sub>LI</sub>	input leakage current	V <sub>i</sub> = 0 to V <sub>DD</sub>	-10	-	+10	μA
SCL						
V <sub>IL</sub>	LOW level input voltage		-0.3	-	+1.5	V
V <sub>IH</sub>	HIGH level input voltage		3.0	-	V <sub>DD</sub> + 0.5	V
I <sub>LI</sub>	input leakage current	V <sub>i</sub> = 0 to V <sub>DD</sub>	-10	-	+10	μA
f <sub>SCL</sub>	clock frequency		0	-	100	kHz
t <sub>r</sub>	input rise time	10% to 90%	-	-	2	μs
t <sub>f</sub>	input fall time	90% to 10%	-	-	2	μs
C <sub>i</sub>	input capacitance		-	-	10	pF
<b>Inputs/outputs</b>						
CRYSTAL OSCILLATOR (OSCIN; OSCOUT)						
f <sub>XTAL</sub>	crystal frequency		-	27	-	MHz
G <sub>v</sub>	small signal voltage gain		3.5	-	-	
G <sub>m</sub>	mutual conductance	f <sub>i</sub> = 100 kHz	1.5	-	-	mA/V
C <sub>i</sub>	input capacitance		-	-	10	pF
C <sub>FB</sub>	feedback capacitance		-	-	5	pF
BLACK						
C <sub>blk</sub>	storage capacitor to ground		-	100	-	nF
I <sub>LI</sub>	input leakage current	V <sub>i</sub> = 0 to V <sub>DD</sub>	-10	-	+10	μA
SDA						
V <sub>IL</sub>	LOW level input voltage		-0.3	-	+1.5	V
V <sub>IH</sub>	HIGH level input voltage		3.0	-	V <sub>DD</sub> + 0.5	V
I <sub>LI</sub>	input leakage current	V <sub>i</sub> = 0 to V <sub>DD</sub>	-10	-	+10	μA
C <sub>i</sub>	input capacitance		-	-	10	pF
t <sub>r</sub>	input rise time	10% to 90%	-	-	2	μs
t <sub>f</sub>	input fall time	90% to 10%	-	-	2	μs
V <sub>OL</sub>	LOW level output voltage	I <sub>OL</sub> = 3 mA	0	-	0.5	V
t <sub>f</sub>	output fall time	3 V to 1 V	-	-	200	ns
C <sub>L</sub>	load capacitance		-	-	400	pF

# Integrated VIP and Teletext with Background Memory Controller (IVT1.1BMCX)

SAA5249

SYMBOL	PARAMETER	CONDITIONS	MIN.	TYP.	MAX.	UNIT
<b>D0 TO D3</b>						
V <sub>IL</sub>	LOW level input voltage		-0.3	-	+0.8	V
V <sub>IH</sub>	HIGH level input voltage		2.0	-	V <sub>DD</sub> + 0.5	V
I <sub>LI</sub>	input leakage current		-10	-	+10	μA
C <sub>i</sub>	input capacitance		-	-	10	pF
V <sub>OL</sub>	LOW level output voltage	I <sub>OL</sub> = +1.6 mA	0	-	0.4	V
V <sub>OH</sub>	HIGH level output voltage	I <sub>OH</sub> = -0.2 mA	2.4	-	V <sub>DD</sub>	V
t <sub>r</sub>	output rise time	0.6 to 2.2 V	-	-	20	ns
t <sub>f</sub>	output fall time	2.2 to 0.6 V	-	-	20	ns
C <sub>L</sub>	load capacitance		-	-	50	pF
<b>Outputs</b>						
<b>STTV</b>						
G <sub>stt</sub>	gain of STTV relative to video input		0.9	1.0	1.1	
V <sub>TCS</sub>	TCS amplitude		0.2	0.3	0.45	V
V <sub>DCs</sub>	DC shift between TCS output and nominal video output		-	-	0.15	V
I <sub>O</sub>	output drive current		-	-	3.0	mA
C <sub>L</sub>	load capacitance		-	-	100	pF
<b>A0 TO A9 ADDRESS OUTPUT TO MEMORY A0 TO A9</b>						
V <sub>OL</sub>	LOW level output voltage	I <sub>OL</sub> = +1.6 mA	0	-	0.4	V
V <sub>OH</sub>	HIGH level output voltage	I <sub>OH</sub> = -0.2 mA	2.4	-	V <sub>DD</sub>	V
C <sub>L</sub>	load capacitance		-	-	50	pF
t <sub>r</sub>	output rise time	0.6 to 2.2 V	-	-	20	ns
t <sub>f</sub>	output fall time	2.2 to 0.6 V	-	-	20	ns
<b>R/W, CAS0 AND CAS1</b>						
V <sub>OL</sub>	LOW level output voltage	I <sub>OL</sub> = +1.6 mA	0	-	0.4	V
V <sub>OH</sub>	HIGH level output voltage	I <sub>OH</sub> = -0.2 mA	2.4	-	V <sub>DD</sub>	V
C <sub>L</sub>	load capacitance		-	-	50	pF
t <sub>r</sub>	output rise time	0.6 to 2.2 V	-	-	20	ns
t <sub>f</sub>	output fall time	2.2 to 0.6 V	-	-	20	ns

# Integrated VIP and Teletext with Background Memory Controller (IVT1.1BMCX)

SAA5249

SYMBOL	PARAMETER	CONDITIONS	MIN.	TYP.	MAX.	UNIT
R, G AND B						
V <sub>OL</sub>	LOW level output voltage	I <sub>OL</sub> = 2 mA	0	–	0.2	V
V <sub>OH</sub>	HIGH level output voltage	I <sub>OH</sub> = –1.6 mA; RGBREF ≤ V <sub>DD</sub> – 2 V	RGBREF –0.25	RGBREF	RGBREF +0.25	V
Z <sub>o</sub>	output impedance		–	–	200	Ω
C <sub>L</sub>	load capacitance		–	–	50	pF
I <sub>DC</sub>	DC current		–	–	–3.3	mA
t <sub>r</sub>	output rise time	10% to 90%	–	–	20	ns
t <sub>f</sub>	output fall time	90% to 10%	–	–	20	ns
BLANK						
V <sub>OL</sub>	LOW level output voltage	I <sub>OL</sub> = 1.6 mA	0	–	0.4	V
V <sub>OH</sub>	HIGH level output voltage	I <sub>OH</sub> = –0.2 mA; V <sub>DD</sub> = 4.5 V	1.1	–	–	V
V <sub>OH</sub>	HIGH level output voltage	I <sub>OH</sub> = 0 mA; V <sub>DD</sub> = 5.5 V	–	–	2.8	V
V <sub>OH</sub>	allowed voltage at pin	with external pull-up	–	–	V <sub>DD</sub>	V
C <sub>L</sub>	load capacitance		–	–	50	pF
t <sub>r</sub>	output rise time	10% to 90%	–	–	20	ns
t <sub>f</sub>	output fall time	90% to 10%	–	–	20	ns
ODD/ <u>EVEN</u>						
V <sub>OL</sub>	LOW level output voltage	I <sub>OL</sub> = +1.6 mA	0	–	0.4	V
V <sub>OH</sub>	HIGH level output voltage	I <sub>OH</sub> = –0.2 mA	2.4	–	V <sub>DD</sub>	V
C <sub>L</sub>	load capacitance		–	–	120	pF
t <sub>r</sub>	output rise time	0.6 to 2.2 V	–	–	50	ns
t <sub>f</sub>	output fall time	2.2 to 0.6 V	–	–	50	ns
<u>COR</u> AND Y (OPEN-DRAIN)						
V <sub>OH</sub>	pull-up voltage at pin		–	–	V <sub>DD</sub>	V
V <sub>OL</sub>	output voltage LOW	I <sub>OL</sub> = 5 mA	0	–	1.0	V
C <sub>L</sub>	load capacitance		–	–	25	pF
t <sub>f</sub>	output fall time	load resistor of 1.2 kΩ to V <sub>DD</sub> ; measured between V <sub>DD</sub> – 0.5 V and 1.5 V	–	–	50	ns
I <sub>LO</sub>	output leakage current	V <sub>i</sub> = 0 to V <sub>DD</sub>	–10	–	+10	μA
t <sub>skew</sub>	skew delay between display outputs R, G, B, <u>COR</u> , Y and BLANK		–	–	20	ns

# Integrated VIP and Teletext with Background Memory Controller (IVT1.1BMCX)

SAA5249

SYMBOL	PARAMETER	CONDITIONS	MIN.	TYP.	MAX.	UNIT
<b>Timing</b>						
DRAM INTERFACE						
$t_{RC}$	read or write cycle time		344	380	415	ns
$t_{RP}$	$\overline{RAS}$ precharge time		125	140	155	ns
$t_{RAS}$	$\overline{RAS}$ pulse width		194	210	230	ns
$t_{CAS}$	$\overline{CAS}$ pulse width		113	133	153	ns
$t_{ASR}$	row address set-up time		30	60	80	ns
$t_{RAH}$	row address hold time		50	60	92	ns
$t_{ASC}$	column address set-up time		50	60	75	ns
$t_{CAH}$	column address hold time		50	60	70	ns
$t_{RCD}$	$\overline{RAS}$ to $\overline{CAS}$ delay time		130	148	160	ns
$t_{RAD}$	$\overline{RAS}$ to column address delay time		60	74	105	ns
$t_{RSH}$	$\overline{RAS}$ hold time		15	60	70	ns
$t_{CSH}$	$\overline{CAS}$ hold time		260	286	300	ns
$t_{CRP}$	$\overline{CAS}$ to $\overline{RAS}$ precharge time		60	70	80	ns
$t_{DZO}$	$\overline{CAS}$ set-up time from data input		200	225	280	ns
$t_r, t_f$	rise and fall times		10	15	20	ns
$t_{WCS}$	write set-up time		193	212	235	ns
$t_{WCH}$	write command hold time		116	137	150	ns
$t_{DS}$	data input set-up time		193	212	235	ns
$t_{DH}$	data input hold time		42	62	80	ns
$t_{RAC}$	access time from $\overline{RAS}$		165	183	220	ns
$t_{CAC}$	access time from $\overline{CAS}$		0	35	40	ns
$t_{AA}$	access time from address		95	108	120	ns
$t_{RCS}$	read command set-up time		193	212	235	ns
$t_{RCH}$	read command hold time to $\overline{CAS}$		0	10	20	ns
$t_{RRH}$	read command hold time to $\overline{RAS}$		55	65	100	ns
$t_{RAL}$	column address to $\overline{RAS}$ lead time		90	133	150	ns
$t_{OFF1}$	output buffer turn-off time		20	30	40	ns
$t_{CDD}$	$\overline{CAS}$ to data input delay time		25	35	45	ns

# Integrated VIP and Teletext with Background Memory Controller (IVT1.1BMCX)

SAA5249

SYMBOL	PARAMETER	CONDITIONS	MIN.	TYP.	MAX.	UNIT
I <sup>2</sup> C-BUS						
t <sub>LOW</sub>	clock LOW period		4	–	–	μs
t <sub>HIGH</sub>	clock HIGH period		4	–	–	μs
t <sub>SU;DAT</sub>	data set-up time		250	–	–	ns
t <sub>HD;DAT</sub>	data hold time		170	–	–	ns
t <sub>SU;STO</sub>	set-up time from clock HIGH to STOP		4	–	–	μs
t <sub>BUF</sub>	START set-up time following a STOP		4	–	–	μs
t <sub>HD;STA</sub>	START hold time		4	–	–	μs
t <sub>SU;STA</sub>	START set-up time following clock LOW-to-HIGH transition		4	–	–	μs

## Notes

1. This current is the maximum allowed into the inputs when line and field flyback signals are connected to these inputs. Series current limiting resistors must be used to limit the input currents to  $\pm 1$  mA.
2. RGBREF is the positive supply pin for the RGB output pins and it must be able to source the I<sub>OH</sub> current from the R, G and B pins. The leakage specification on RGBREF only applies when there is no current load on the RGB pins.

# Integrated VIP and Teletext with Background Memory Controller (IVT1.1BMCX)

SAA5249

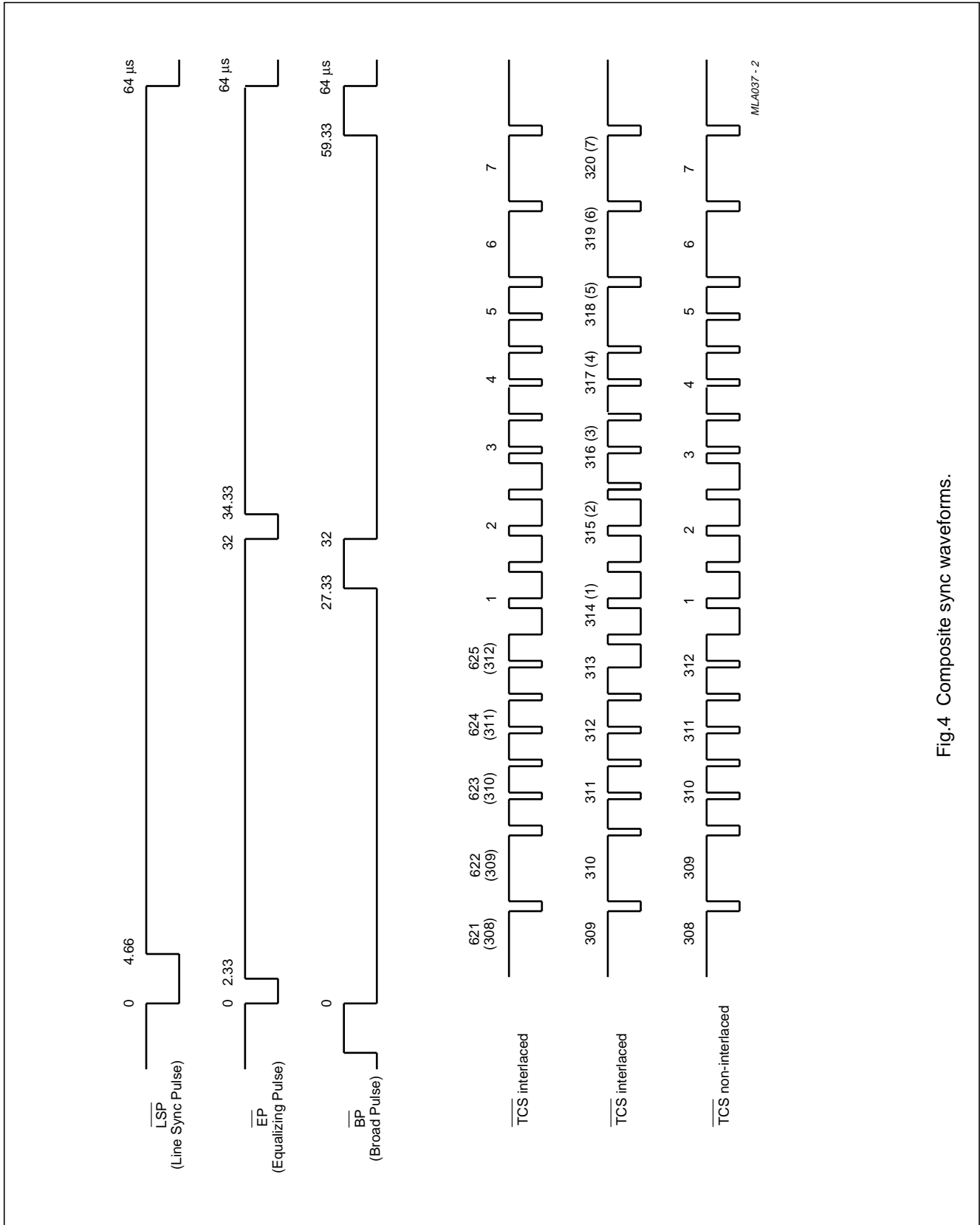

Fig. 4 Composite sync waveforms.



Integrated VIP and Teletext with Background  
Memory Controller (IVT1.1BMCX)

SAA5249

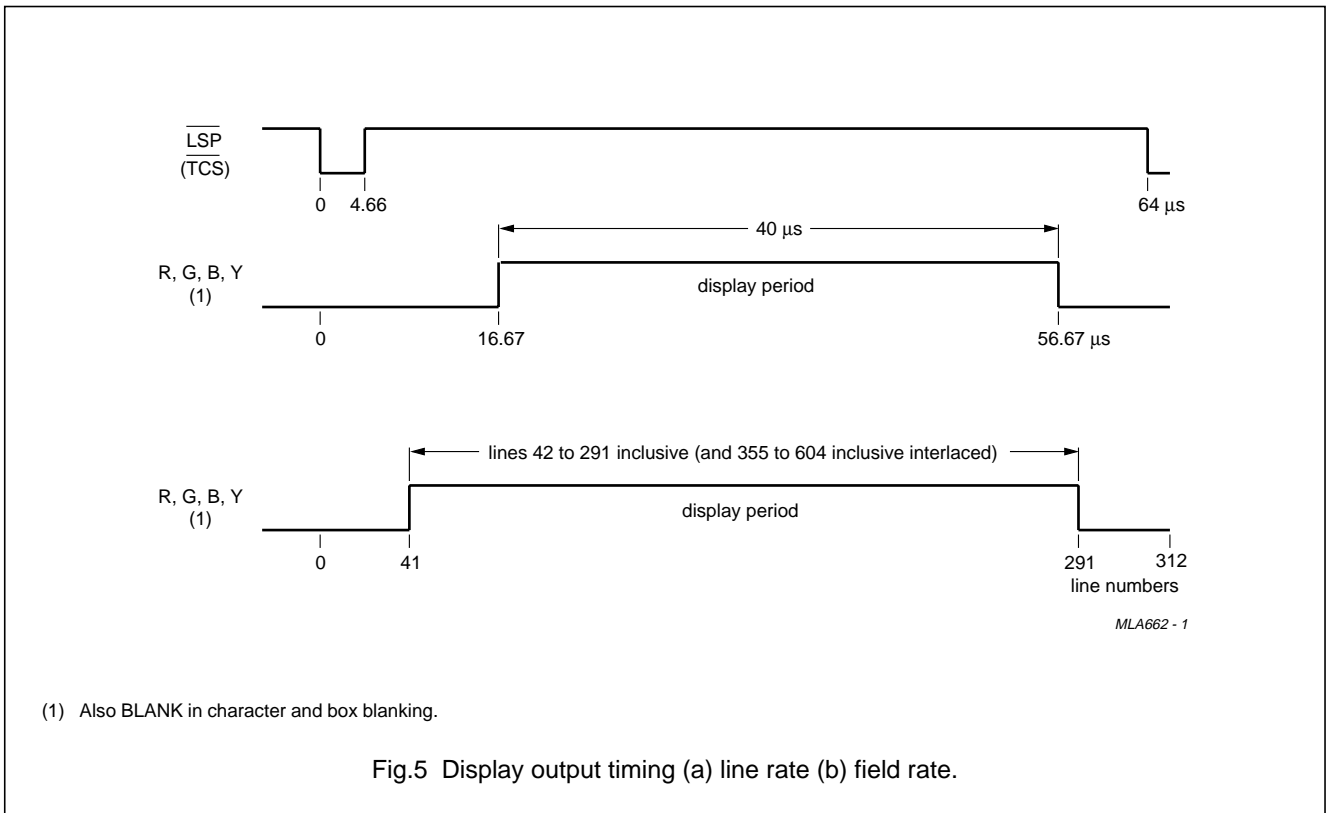

Fig.5 Display output timing (a) line rate (b) field rate.

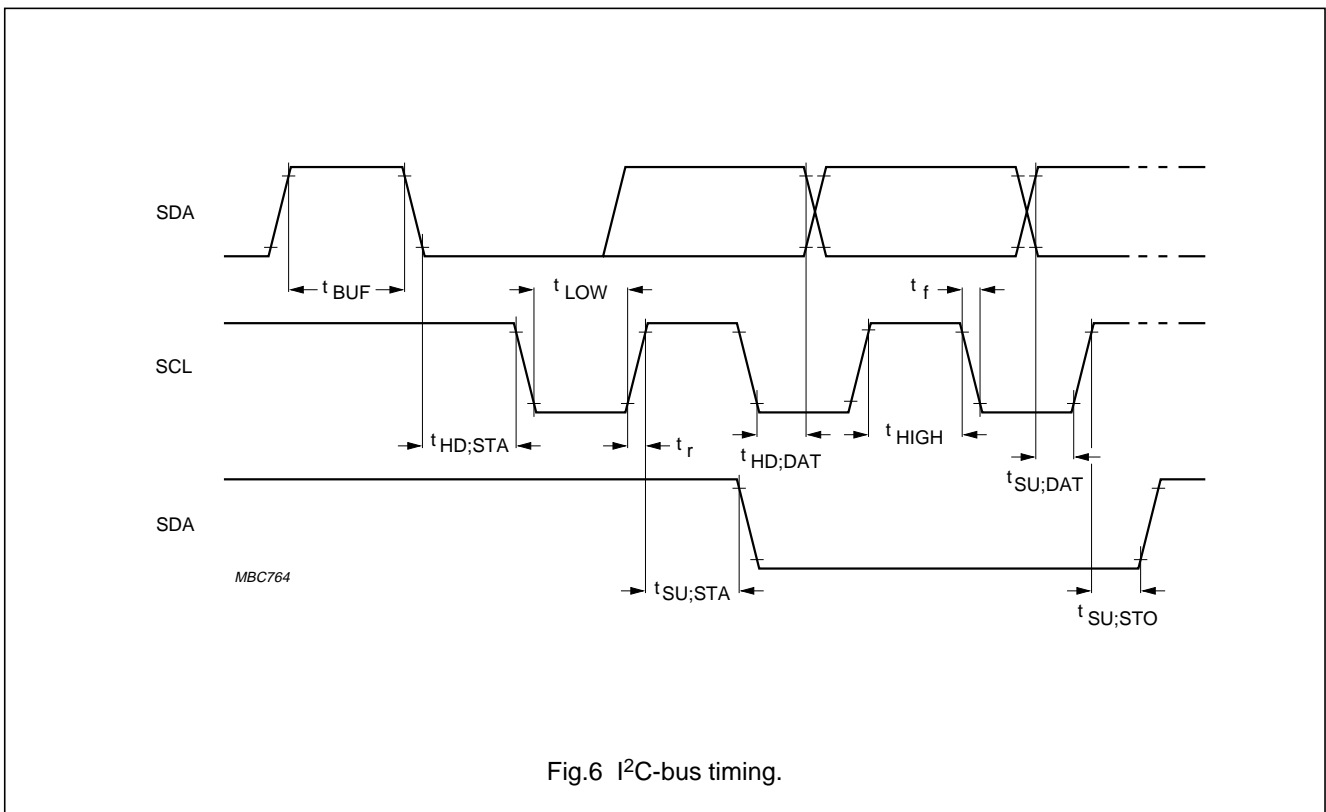
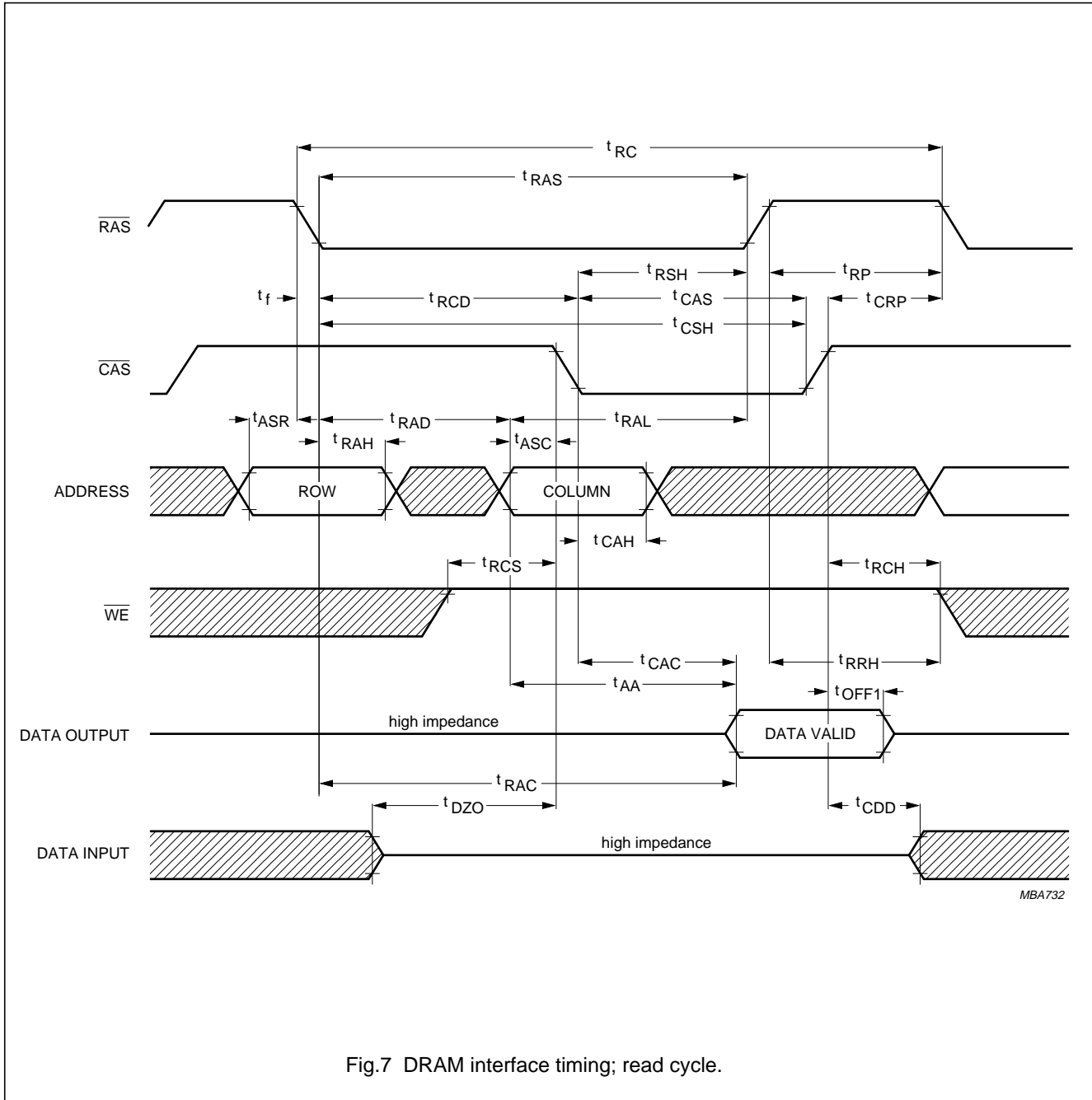

Fig.6 I<sup>2</sup>C-bus timing.

# Integrated VIP and Teletext with Background Memory Controller (IVT1.1BMCX)

SAA5249



# Integrated VIP and Teletext with Background Memory Controller (IVT1.1BMCX)

SAA5249

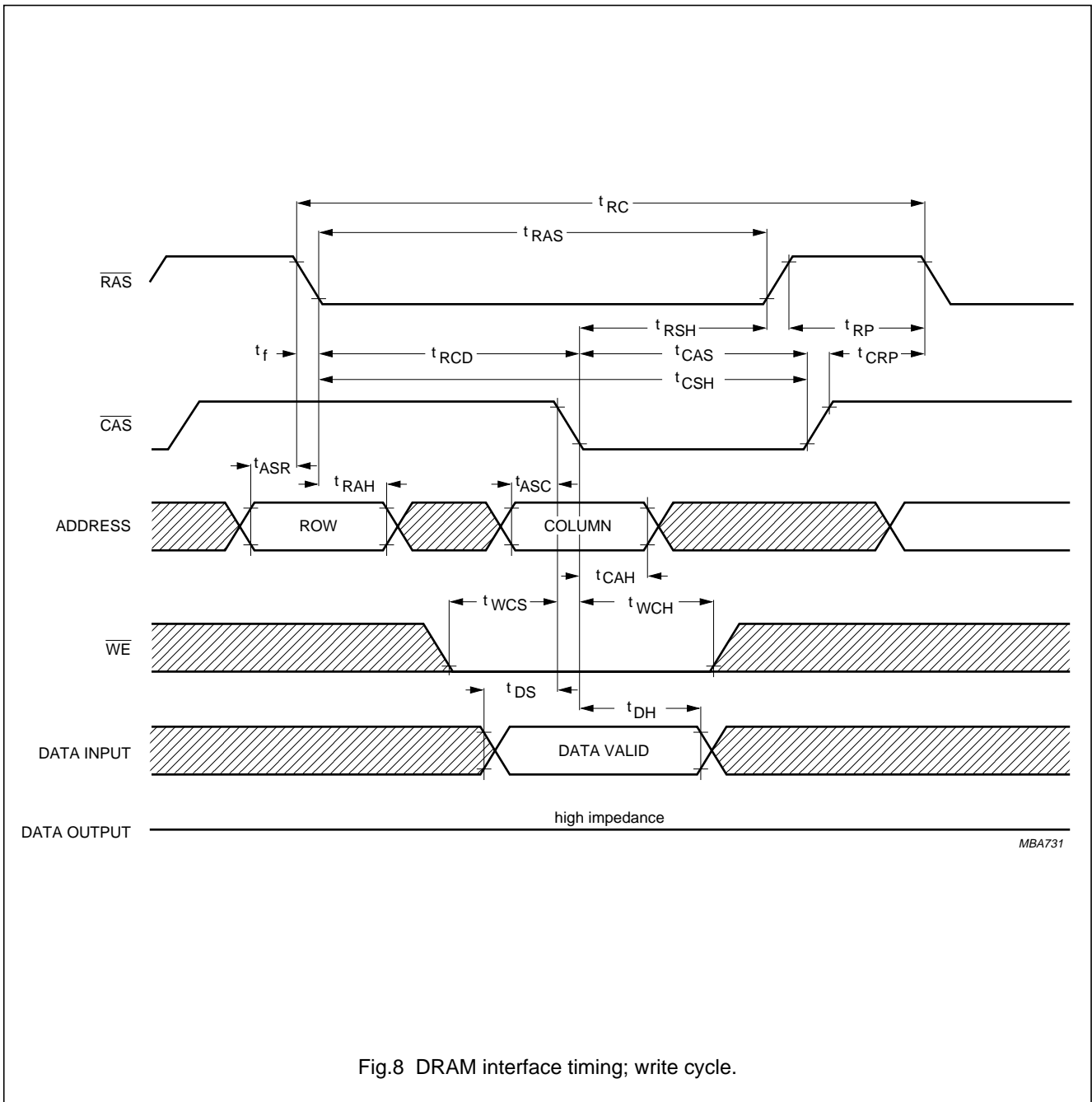

Integrated VIP and Teletext with Background Memory Controller (IVT1.1BMCX)

SAA5249

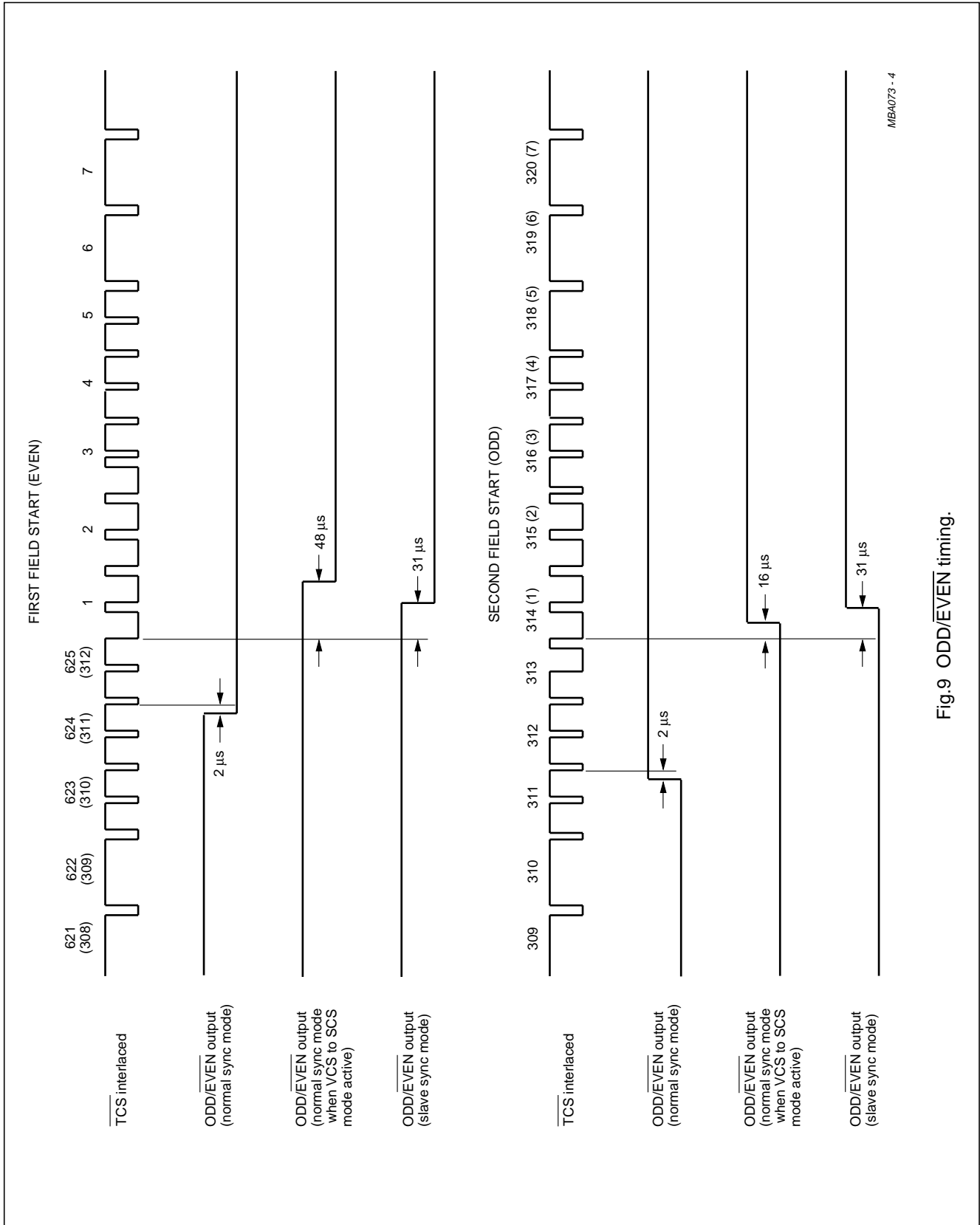

Fig.9 ODD/EVEN timing.

# Integrated VIP and Teletext with Background Memory Controller (IVT1.1BMCX)

SAA5249

## APPLICATION INFORMATION

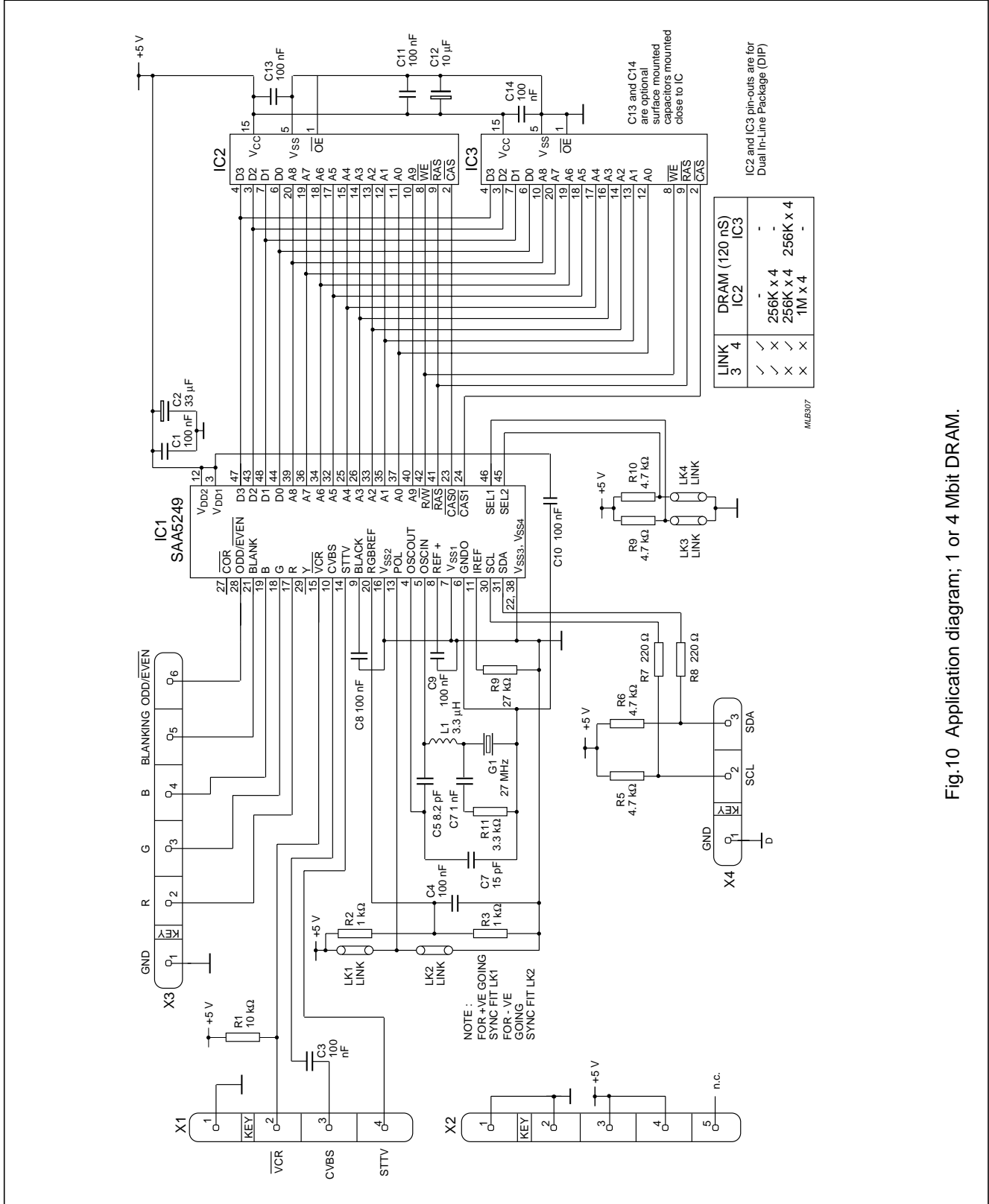

Fig.10 Application diagram; 1 or 4 Mbit DRAM.

# Integrated VIP and Teletext with Background Memory Controller (IVT1.1BMCX)

SAA5249

## IVT1.1BMCX page memory organization

The organization of the page memory is illustrated by Fig.11. The IVT1.1BMCX provides an additional row as compared with first generation decoders; this brings the display format up to 40 characters by 25 rows. Rows 0 to 23 form the teletext page; Row 24 is the extra row available for software generated status messages and FLOF/FASTEXT prompt information.

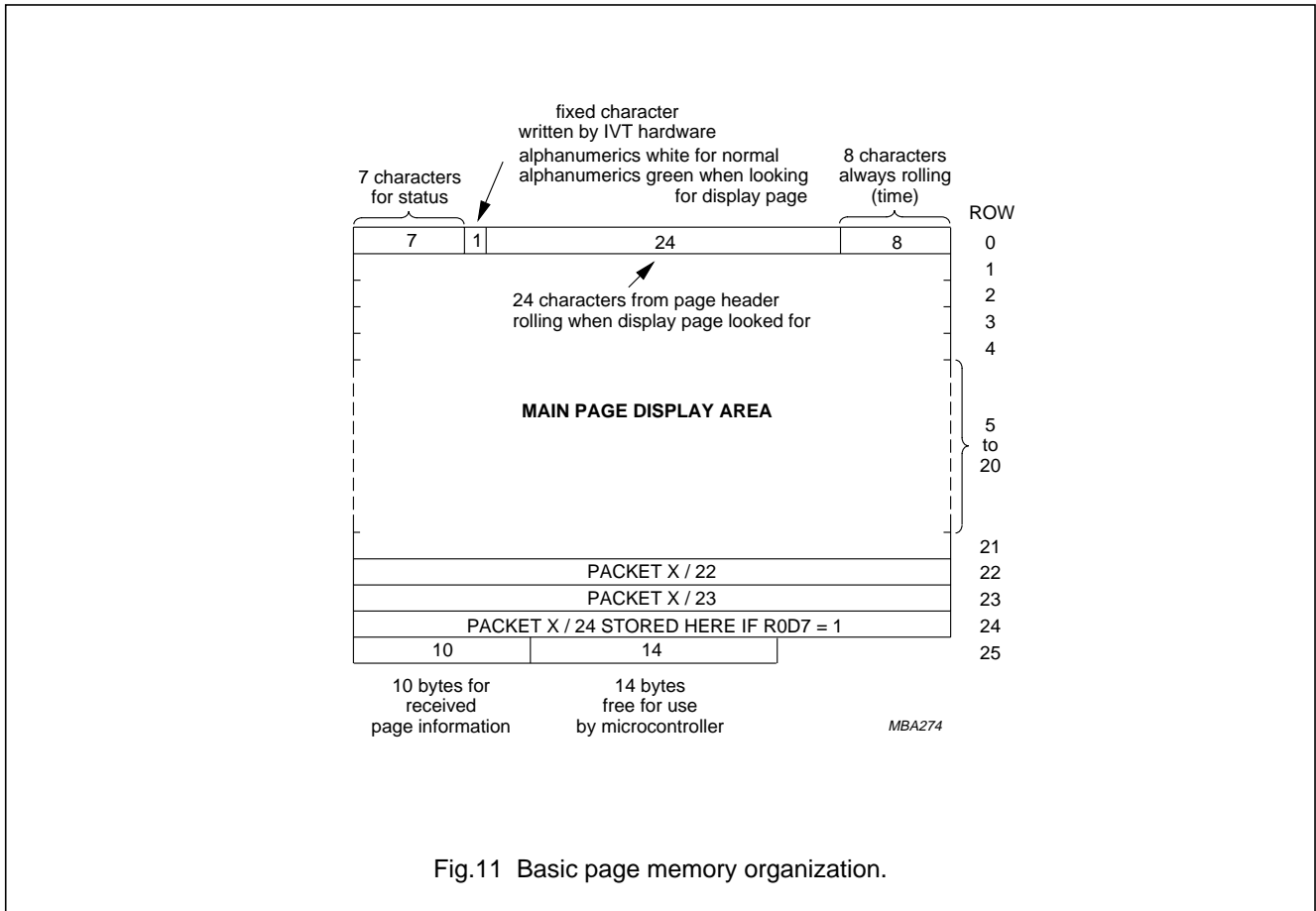

Fig.11 Basic page memory organization.

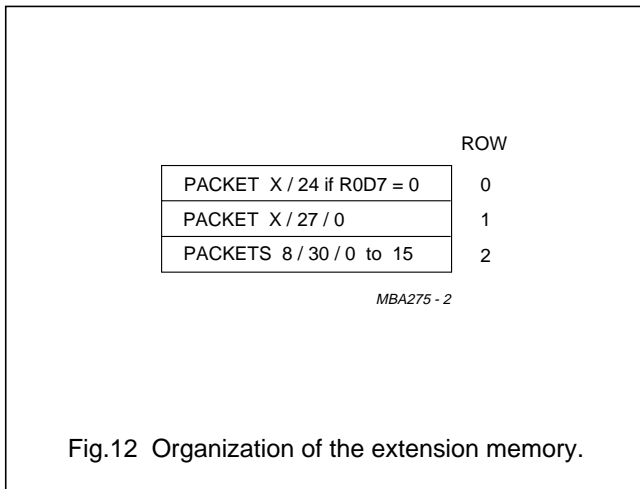

Fig.12 Organization of the extension memory.

REMARK TO Fig.11

### Row 0

Row 0 is for the page header. The first seven columns (0 to 6) are free for status messages. The eighth is an alphanumeric white or green control character, written automatically by IVT1.1BMCX to give a green rolling header when a page is being looked for. The last eight characters are for rolling time.

### Row 25

The first 10 bytes of row 25 contain control data relating to the received page as shown in Table 5. The remaining 14-bytes are free for use by the microcomputer.

**Integrated VIP and Teletext with Background  
Memory Controller (IVT1.1BMCX)**

**SAA5249**

**Table 5** Row 25 received control data format

D0	PU0	PT0	MU0	MT0	HU0	HT0	C7	C11	MAG0	0
D1	PU1	PT1	MU1	MT1	HU1	HT1	C8	C12	MAG1	0
D2	PU2	PT2	MU2	MT2	HU2	C5	C9	C13	MAG2	0
D3	PU3	PT3	MU3	C4	HU3	C6	C10	C14	0	0
D4	HAM.ER	HAM.ER	HAM.ER	HAM.ER	HAM.ER	HAM.ER	HAM.ER	HAM.ER	$\overline{\text{FOUND}}$	0
D5	0	0	0	0	0	0	0	0	0	PBLF
D6	0	0	0	0	0	0	0	0	0	0
D7	0	0	0	0	0	0	0	0	0	0
Column	0	1	2	3	4	5	6	7	8	9

**Table 6** Page number and sub-code for Table 5

<b>Page number</b>	
MAG	magazine
PU	page units
PT	page tens
PBLF	page being looked for
$\overline{\text{FOUND}}$	LOW for page has been found
HAM.ER	hamming error in corresponding byte
<b>Page sub-code</b>	
MU	minutes units
MT	minutes tens
HU	hours units
HT	hours tens
C4 to C14	transmitted control bits

# Integrated VIP and Teletext with Background Memory Controller (IVT1.1BMCX)

SAA5249

## Register maps

IVT1.1BMCX mode registers R0 to R11 are shown in Table 7. R0 to R10 are write only; R11 is read/write. Register map (R3), for page requests, is shown in detail in Table 9.

**Table 7** Register map (notes 1 to 5)

REGISTER		D7	D6	D5	D4	D3	D2	D1	D0
Adv. control	0	X24 POS	FREE RUN PLL	AUTO ODD/ EVEN	DISABLE HDR ROLL	DISPLAY SRATUS ROW ONLY	DISABLE ODD/ EVEN	–	R11/R11B SELECT
Mode	1	VCS TO SCS	7 + P/ 8-BIT	ACQ ON/OFF	DISABLE PKT 26	DEW/ FULL FIELD	TCS ON	T1	T0
Page request address	2	–	–	–	–	TB	START COLUMN SC2	START COLUMN SC1	START COLUMN SC0
Page request data	3	–	–	CLEAR B.M.	PRD4	PRD3	PRD2	PRD1	PRD0
		–	–	–	–	–	–	–	–
Display control (normal)	5	BKGND OUT	BKGND IN	COR OUT	COR IN	TEXT OUT	TEXT IN	PON OUT	PON IN
Display control (newsflash /subtitle)	6	BKGND OUT	BKGND IN	COR OUT	COR IN	TEXT OUT	TEXT IN	PON OUT	PON IN
Display mode	7	STATUS BTM TOP	CURSOR ON	CONCEA L REVEAL ON	TOP/BTM HALF	SINGLE DOUBLE HEIGHT	BOX ON 24	BOX ON 1-23	BOX ON 0
		–	–	–	–	–	–	–	–
Cursor row	9	–	CLEAR MEM.	A0	R4	R3	R2	R1	R0
Cursor column	10	–	–	C5	C4	C3	C2	C1	C0
Cursor data	11	D7	D6	D5	D4	D3	D2	D1	D0
Device status	11B	625/525 SYNC	ROM VER R4	ROM VER R3	ROM VER R2	ROM VER R1	ROM VER R0	TEXT SIGNAL QUALITY	VCS SIGNAL QUALITY



# Integrated VIP and Teletext with Background Memory Controller (IVT1.1BMCX)

SAA5249

## Notes

1. The dash (–) indicates these bits are inactive and must be written to logic 0 for future compatibility.
2. All bits in registers R0 to R10 are cleared to logic 0 on power-up except bits D0 and D1 of Registers R1, R5 and R6 which are set to logic 1.
3. All memory is cleared to space (00100000) on power-up, except Row 0 Column 7 Chapter 0, which is alpha white (00000111) as the acquisition circuit is enabled but the page is on hold.
4. TB must be set to logic 0 for normal operation.
5. The I<sup>2</sup>C-bus slave address is 0010001.

**Table 8** Register description

<b>R0 ADVANCED CONTROL - auto increments to register 1</b>	
R11/R11B SELECT	selects reading of R11 or R11B
DISABLE ODD/ $\overline{\text{EVEN}}$	forces ODD/ $\overline{\text{EVEN}}$ output LOW when logic 1
DISPLAY STATUS ROW	when SET = 1 and R1D6 = 1 open (8-bit mode) then all the text display is blanked out apart from the status row, this allows the page memory to be used for non-textural data, such as in the German TOP system
DISABLE HDR ROLL	disables green rolling header and time
AUTO ODD/ $\overline{\text{EVEN}}$	when set forces ODD/ $\overline{\text{EVEN}}$ LOW if any TV picture displayed, if DISABLE ODD/ $\overline{\text{EVEN}}$ = 0
FREE RUN PLL	will force the PLL to free run in all conditions
X24 POS	automatic display of FASTEXT prompt row when logic 1
<b>R1 MODE - auto increments to register 2</b>	
T0, T1	interlace/non-interlace 312/313 line control (see Table 10)
TCS ON	text composite sync or direct sync select (see Table 10 for FFB mode selection)
$\overline{\text{DEW}}$ /FULL FIELD	field-flyback or full-channel mode
DISABLE PKT 26	disable automatic processing of packet 26
ACQ $\overline{\text{ON}}$ /OFF	acquisition circuits turned off when logic 1
$\overline{7 + P}$ /8-BIT	7-bits with parity checking or 8-bit mode
VCS TO SCS	when logic 1 enables display of messages with 60 Hz input signal
<b>R2 PAGE REQUEST ADDRESS - auto increments to register 3</b>	
COL SCO - SC2	point to start column for page request data (see Table 9)
TB	must be logic 0 for normal operation
<b>R3 PAGE REQUEST DATA - does not auto increment (see Table 9)</b>	
CLEAR B.M.	when set to logic 1. Useful when transmission channel changes
<b>R5 NORMAL DISPLAY CONTROL - auto increments to register 6</b>	
<b>R6 NEWSFLASH/SUBTITLE DISPLAY CONTROL - auto increments to register 7; (note 1)</b>	
PON	picture on
TEXT	text on
COR	contrast reduction on
BKGND	background colour on

## Integrated VIP and Teletext with Background Memory Controller (IVT1.1BMCX)

SAA5249

<b>R7 DISPLAY MODE - does not auto increment</b>	
BOX ON 0	boxing function allowed on Row 0
BOX ON 1-23	boxing function allowed on Rows 1 to 23
BOX ON 24	boxing function allowed on Row 24
DOUBLE HEIGHT	to display double height text
BOTTOM HALF	to select bottom half of page when DOUBLE HEIGHT = 1
REVEAL ON	to reveal concealed text
CURSOR ON	to display cursor
STATUS TOP	row 25 displayed above or below the main text
<b>R9 CURSOR ROW - auto increments to register 10</b>	
R0 to R4	active row for data written to or read from memory via the I <sup>2</sup> C-bus
A0	selects display memory page (when = 0) or extension packet memory (when = 1)
CLEAR MEM.	when set to 1, clears the display memory; this bit is automatically reset
<b>R10 CURSOR COLUMN - auto increments to register 11 or 11B</b>	
C0 to C5	active column for data written to or read from memory via the I <sup>2</sup> C-bus
<b>R11 CURSOR DATA - does not auto increment</b>	
D0 to D7	data read from/written to memory via I <sup>2</sup> C-bus, at location pointed to by R9 and R10. This location automatically increments each time R11 is accessed
<b>R11B DEVICE STATUS - does not auto increment</b>	
VCS SIGNAL QUALITY	indicates that the video signal quality is good and PLL is phase locked to input video when = 1
TEXT SIGNAL QUALITY	if a good teletext signal is being received when logic 1
ROM VER R0 to R4	indicated language/ROM variant. For Western European = 11 000
625/525 SYNC	if the input video is a 525 line signal when logic 1

**Note**

1. These functions have IN and OUT referring to inside and outside the boxing function respectively.

# Integrated VIP and Teletext with Background Memory Controller (IVT1.1BMCX)

SAA5249

**Table 9** Register map for page requests (R3); notes 1 to 5

START COLUMN	PRD4	PRD3	PRD2	PRD1	PRD0
0	DO CARE magazine	$\overline{\text{HOLD}}$	MAG2	MAG1	MAG0
1	DO CARE page tens	PT3	PT2	PT1	PT0
2	DO CARE page units	PU3	PU2	PU1	PU0
3	DO CARE hours tens	X	X	HT1	HT0
4	DO CARE hours units	HU3	HU2	HU1	HU0
5	DO CARE minutes tens	X	MT2	MT1	MT0
6	DO CARE minutes units	MU3	MU2	MU1	MU0

**Notes**

- Abbreviations are as for Table 5 except for DO CARE bits.
- When the DO CARE bit is set to logic 1 this means the corresponding digit is to be taken into account for page requests. If the DO CARE bit is set to logic 0 the digit is ignored. This allows, for example, normal or timed page selection.
- If  $\overline{\text{HOLD}}$  is set LOW, the page is held and not updated.
- Columns auto-increment on successive I<sup>2</sup>C-bus transmission bytes.
- X = don't care.

**Table 10** Interlace/non-interlace 312/313 line control and ODD/EVEN field detection option; notes 1 and 2

TCS ON FFB MODE	T1	T0	RESULT
X	0	0	interlaced 312.5/312.5 lines
X	0	1	non-interlaced 312/313 lines (note 1)
X	1	0	non-interlaced 312/313 lines (note 1)
0	1	1	SCS (scan composite sync) mode: FFB leading edge in first broad pulse of field
1	1	1	SCS (scan composite sync) mode: FFB leading edge in second broad pulse of field

**Notes**

- Reverts to interlaced mode if a newflash or subtitle is being displayed.
- X = Don't care.

**Integrated VIP and Teletext with Background  
Memory Controller (IVT1.1BMCX)**

**SAA5249**

**CLOCK SYSTEMS**

**Crystal oscillator**

The crystal is a conventional 2-pin design operating at 27 MHz. It is capable of oscillating with both fundamental and third overtone mode crystals. External components should be used to suppress the fundamental output of the third overtone as illustrated in Fig.13.

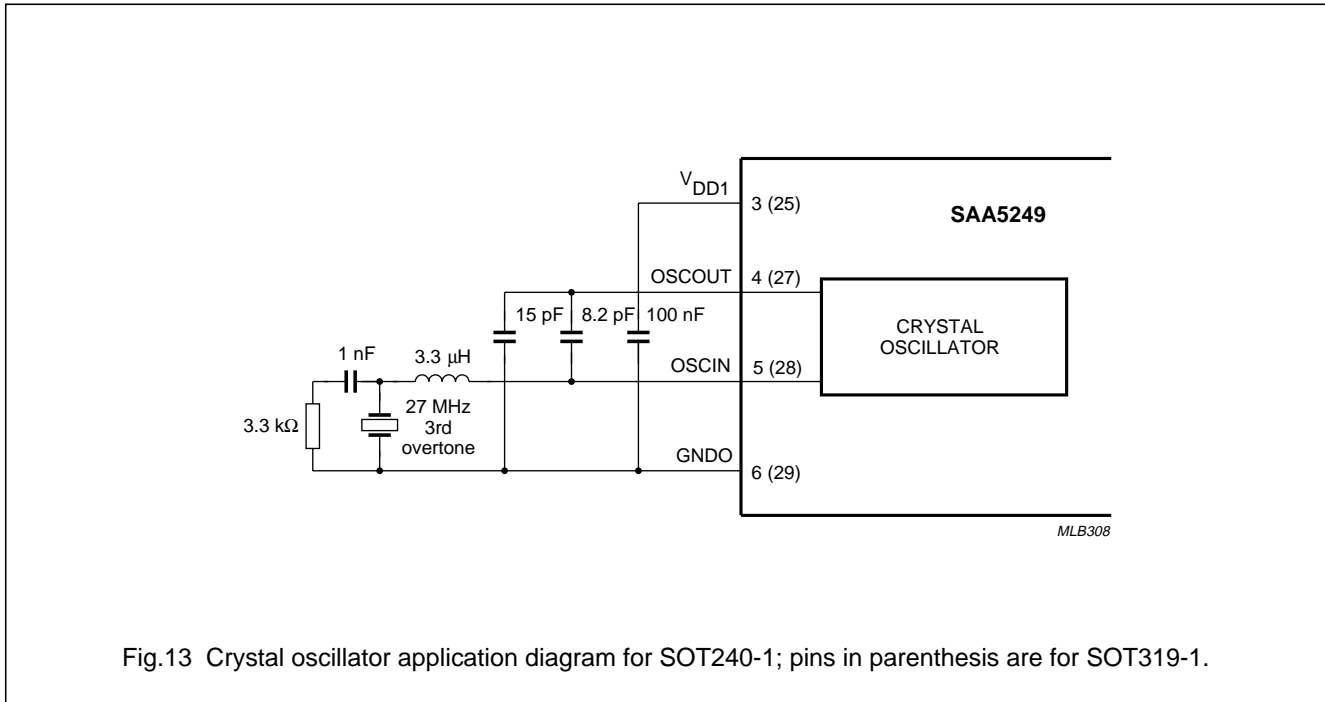

Fig.13 Crystal oscillator application diagram for SOT240-1; pins in parenthesis are for SOT319-1.

**Table 11** Crystal characteristics (see Fig.13)

SYMBOL	PARAMETER	MIN.	TYP.	MAX.	UNIT
<b>Crystal (27 MHz, 3rd overtone)</b>					
C1	series capacitance	–	1.7	–	pF
C0	parallel capacitance	–	5.2	–	pF
C <sub>L</sub>	load capacitance	–	20	–	pF
R <sub>r</sub>	resonance resistance	–	–	50	Ω
R1	series resistance	–	20	–	Ω
X <sub>a</sub>	ageing	–	–	±5	10 <sup>-6</sup> /year
X <sub>j</sub>	adjustment tolerance	–	–	±25	10 <sup>-6</sup>
X <sub>d</sub>	drift	–	–	±25	10 <sup>-6</sup>

# Integrated VIP and Teletext with Background Memory Controller (IVT1.1BMCX)

SAA5249

## CHARACTER SETS

The WST specification allows the selection of national character sets via the page header transmission bits, C12 to C14. The basic 96 character sets differ only in 13 national option characters as indicated in the Tables 16, 17 and 18 with reference to their table position in the basic character matrix illustrated in Table 15. The IVT1.1BMCX automatically decodes transmission bits C12 to C14. Tables 12, 13 and 14 illustrate the character matrices.

Character bytes are listed as transmitted from b1 to b7.

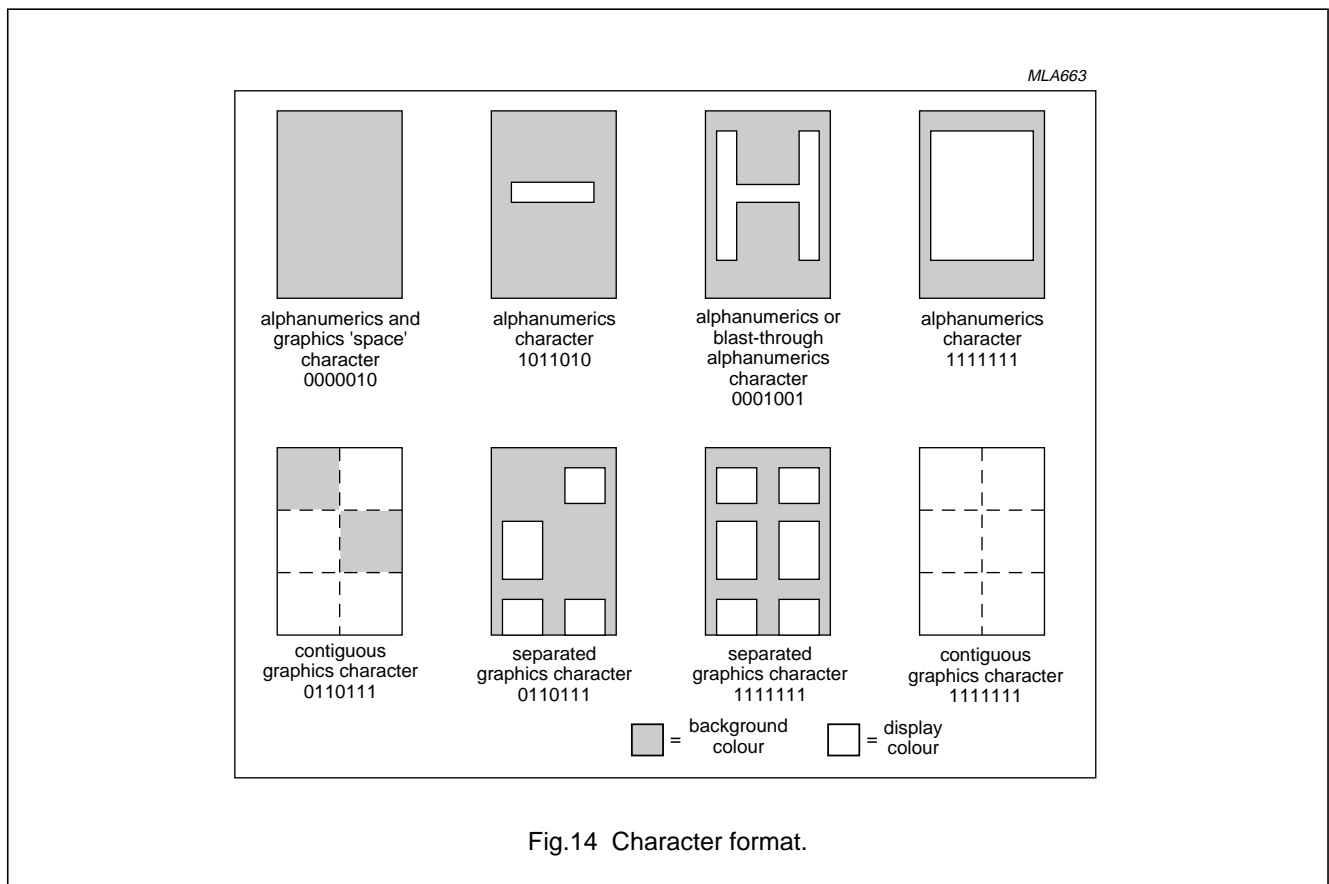

# Integrated VIP and Teletext with Background Memory Controller (IVT1.1BMCX)

SAA5249

**Table 12** SAA5249P/E character data input decoding, West European languages; notes 1 to 9  
For character version number (11000) see Register 11B.

BITS	column																						
	b <sub>8</sub>	b <sub>7</sub>	b <sub>6</sub>	b <sub>5</sub>	0	1	2	2a	3	3a	4	5	6	6a	7	7a	8	9	12	13	14	15	
0 0 0 0	0	0	0	0	alpha - numerics black	graphics black			0		Š P °		p		@	É é	à	i	Á				
0 0 0 1	0	0	0	1	alpha - numerics red	graphics red	!		1		A Q a		q		—	é	ù	è	ó	À			
0 0 1 0	0	0	1	0	alpha - numerics green	graphics green	”		2		B R b		r		¼	ä	á	â	ü	È			
0 0 1 1	0	0	1	1	alpha - numerics yellow	graphics yellow	#		3		C S c		s		€	#	€	é	ç	Í			
0 1 0 0	0	1	0	0	alpha - numerics blue	graphics blue	\$		4		D T d		t		\$	X	\$	i	\$	İ			
0 1 0 1	0	1	0	1	alpha - numerics magenta	graphics magenta	%		5		E U e		u		€	€	ä	Å	æ	Ó			
0 1 1 0	0	1	1	0	alpha - numerics cyan	graphics cyan	&		6		F V f		v		€	€	ö	ø	œ	Ò			
0 1 1 1	0	1	1	1	alpha - numerics white <sup>(2)</sup>	graphics white	'		7		G W g		w		?	?	·	Ç	Ñ	Ú			
1 0 0 0	1	0	0	0	flash	conceal display	(		8		H X h		x			ö	ö	ö	ñ	æ			
1 0 0 1	1	0	0	1	steady <sup>(2)</sup>	contiguous graphics <sup>(2)</sup>	)		9		I Y i		y		¾	ä	è	ù	è	Æ			
1 0 1 0	1	0	1	0	end box <sup>(2)</sup>	separated graphics	*		:		J Z j		z		÷	ü	i	ç	à	à			
1 0 1 1	1	0	1	1	start box	ESC <sup>(1)</sup>	+		;		K Ä k		ä		←	Ä	°	ë	á	Ð			
1 1 0 0	1	1	0	0	normal height <sup>(2)</sup>	black back-ground <sup>(2)</sup>	,		<		L Ö l		ö		½	ö	ç	è	é	ø			
1 1 0 1	1	1	0	1	double height	new back-ground	-		=		M Ü m		ü		→	À	→	ù	í	∅			
1 1 1 0	1	1	1	0	SO <sup>(1)</sup>	hold graphics	.		>		N ^ n		ß		↑	Ü	↑	î	ó	þ			
1 1 1 1	1	1	1	1	SI <sup>(1)</sup>	release graphics <sup>(2)</sup>	/		?		O _ o		■		#	_	#	#	ú	þ			

MBA429

# Integrated VIP and Teletext with Background Memory Controller (IVT1.1BMCX)

SAA5249

**Table 13** SAA5249P/H character data input decoding, West European languages; notes 1 to 9  
For character version number (11001) see Register 11B.

BITS b <sub>8</sub> b <sub>7</sub> b <sub>6</sub> b <sub>5</sub> b <sub>4</sub> b <sub>3</sub> b <sub>2</sub> b <sub>1</sub>	row	column																		
		0	1	2	2a	3	3a	4	5	6	6a	7	7a	8	9	12	13	14	15	
0 0 0 0	0	alpha - numerics black	graphics black			0	.	I	P	t	.	p	.	S	E	Č	ř	Č	Ü	
0 0 0 1	1	alpha - numerics red	graphics red	!	°	1	□	A	Q	a	°	q	°	°	é	é	é	é	č	ř
0 0 1 0	2	alpha - numerics green	graphics green	”	°	2	□	B	R	b	°	r	°	ä	ä	á	ž	č	ř	
0 0 1 1	3	alpha - numerics yellow	graphics yellow	#	°	3	□	C	S	c	°	s	°	ö	ü	é	ř	ž	ř	
0 1 0 0	4	alpha - numerics blue	graphics blue	⌘	°	4	□	D	T	d	°	t	°	\$	⌘	ü	ñ	½	ř	
0 1 0 1	5	alpha - numerics magenta	graphics magenta	%	°	5	□	E	U	e	°	u	°	€	€	Á	Ö	Ö	ř	
0 1 1 0	6	alpha - numerics cyan	graphics cyan	&	°	6	□	F	V	f	°	v	°	⊗	⊗	É	Ó	Ö	ř	
0 1 1 1	7	alpha - numerics white <sup>(2)</sup>	graphics white	'	°	7	□	G	W	g	°	w	°	⊗	⊗	í	Ü	Ü	N	
1 0 0 0	8	flash	conceal display	(	°	8	□	H	X	h	°	x	°	ö	ö	ě	š	ž	ř	
1 0 0 1	9	steady	contiguous graphics <sup>(2)</sup>	)	°	9	□	I	Y	i	°	y	°	ü	á	ú	ž	ř	ř	
1 0 1 0	10	end box	separated graphics <sup>(2)</sup>	*	°	:	□	J	Z	j	°	z	°	β	ü	š	ž	š	ř	
1 0 1 1	11	start box	ESC <sup>(1)</sup>	+	°	;	□	K	Ā	k	°	ā	°	Ā	Ā	č	ž	č	ř	
1 1 0 0	12	normal height <sup>(2)</sup>	black back-ground <sup>(2)</sup>	,	°	<	□	L	S	l	°	s	°	ö	ö	ž	š	ž	ř	
1 1 0 1	13	double height	new back-ground	-	°	=	□	M	Ā	m	°	ā	°	Ü	Ā	ý	ž	ř	ř	
1 1 1 0	14	SO <sup>(1)</sup>	hold graphics	.	°	>	□	N	î	n	°	î	°	^	Ü	í	č	š	ř	
1 1 1 1	15	SI <sup>(1)</sup>	release graphics <sup>(2)</sup>	/	°	?	□	O	ı	o	°	ı	°	ı	ı	ř	ó	ě	ě	

MLA961

Integrated VIP and Teletext with Background  
Memory Controller (IVT1.1BMCX)

SAA5249

**Table 14** SAA5249P/T character data input decoding, West European and Turkish languages; notes 1 to 9  
For character version number (11010) see Register 11B.

BITS b <sub>8</sub> b <sub>7</sub> b <sub>6</sub> b <sub>5</sub> b <sub>4</sub> b <sub>3</sub> b <sub>2</sub> b <sub>1</sub>	row		column	0	1	2	2a	3	3a	4	5	6	6a	7	7a	8	9	12	13	14	15	
	0 0 0 0	0	0	0	alpha - numerics black	graphics black	0	0	0	0	0	0	0	0	0	0	0	0	0	0	0	0
0 0 0 1	0	0	1	alpha - numerics red	graphics red	!	1	A	Q	a	q	-	ı	ù	è	ó	à	á	ü	ë	í	â
0 0 1 0	0	0	1	alpha - numerics green	graphics green	"	2	B	R	b	r	¼	§	à	á	ü	ë	í	â	á	ü	ë
0 0 1 1	0	0	1	alpha - numerics yellow	graphics yellow	#	3	C	S	c	s	€	ı	è	é	ç	ı	è	é	ç	ı	è
0 1 0 0	0	1	0	alpha - numerics blue	graphics blue	\$	4	D	T	d	t	\$	ğ	\$	ı	\$	ı	\$	ı	\$	ı	\$
0 1 0 1	0	1	0	alpha - numerics magenta	graphics magenta	%	5	E	U	e	u	€	ı	è	é	ç	ı	è	é	ç	ı	è
0 1 1 0	0	1	1	alpha - numerics cyan	graphics cyan	&	6	F	V	f	v	€	ı	è	é	ç	ı	è	é	ç	ı	è
0 1 1 1	0	1	1	alpha - numerics white	graphics white	'	7	G	W	g	w	€	ı	è	é	ç	ı	è	é	ç	ı	è
1 0 0 0	1	0	0	flash	conceal display	(	8	H	X	h	x	€	ı	è	é	ç	ı	è	é	ç	ı	è
1 0 0 1	1	0	0	steady	contiguous graphics	)	9	I	Y	i	y	€	ı	è	é	ç	ı	è	é	ç	ı	è
1 0 1 0	1	0	1	end box	separated graphics	*	:	J	Z	j	z	€	ı	è	é	ç	ı	è	é	ç	ı	è
1 0 1 1	1	0	1	start box	ESC	+	;	K	Ä	k	ä	€	ı	è	é	ç	ı	è	é	ç	ı	è
1 1 0 0	1	1	0	normal height	black back-ground	,	<	L	Ö	l	ö	€	ı	è	é	ç	ı	è	é	ç	ı	è
1 1 0 1	1	1	0	double height	new back-ground	-	=	M	Ü	m	ü	€	ı	è	é	ç	ı	è	é	ç	ı	è
1 1 1 0	1	1	1	SO	hold graphics	.	>	N	^	n	β	€	ı	è	é	ç	ı	è	é	ç	ı	è
1 1 1 1	1	1	1	SI	release graphics	/	?	O	_	o	□	€	ı	è	é	ç	ı	è	é	ç	ı	è

MBA431



Integrated VIP and Teletext with Background  
Memory Controller (IVT1.1BMCX)

SAA5249

**Table 15** SAA5249P/R character data input decoding, Baltic and Cyrillic languages; notes 1 to 9  
For character version number (11101) see Register 11B.

BITS	column				0		1		2		2a		3		3a		4		5		6		6a		7		7a		8		9		12		13		14		15							
	b <sub>8</sub>	b <sub>7</sub>	b <sub>6</sub>	b <sub>5</sub>	row	0	1	2	2a	3	3a	4	5	6	6a	7	7a	8	9	12	13	14	15	0	1	2	2a	3	3a	4	5	6	6a	7	7a	8	9	12	13	14	15					
0 0 0 0	0	0	0	0	0	alpha - numerics black	graphics black			0	.	Š	P	š	.	p		ā	ī	ū	ņ	ņ	ņ																							
0 0 0 1	0	0	0	1	1	alpha - numerics red	graphics red	!	□	1	□	A	Q	a	□	q	□	Ā	Ī	Ā	Я	я	я																							
0 0 1 0	0	0	1	0	2	alpha - numerics green	graphics green	"	□	2	□	B	R	b	□	r	□	ä	ē	Б	Р	δ	р																							
0 0 1 1	0	0	1	1	3	alpha - numerics yellow	graphics yellow	#	□	3	□	C	S	c	□	s	□	Ē	Ē	Ц	С	ц	с																							
0 1 0 0	0	1	0	0	4	alpha - numerics blue	graphics blue	\$	□	4	□	D	T	d	□	t	□	ō	ķ	Д	Т	д	т																							
0 1 0 1	0	1	0	1	5	alpha - numerics magenta	graphics magenta	%	□	5	□	E	U	e	□	u	□	č	ķ	Е	У	е	у																							
0 1 1 0	0	1	1	0	6	alpha - numerics cyan	graphics cyan	ы	□	6	□	F	V	f	□	v	□	&	↓	Ф	Ж	ф	ж																							
0 1 1 1	0	1	1	1	7	alpha - numerics white	graphics white	'	□	7	□	G	W	g	□	w	□	ğ	↓	Г	В	г	в																							
1 0 0 0	1	0	0	0	8	flash	conceal display	(	□	8	□	H	X	h	□	x	□	ö	А	Х	ь	х	ь																							
1 0 0 1	1	0	0	1	9	steady	(2) contiguous graphics	)	□	9	□	I	Y	i	□	y	□	ų	Ū	И	Ь	и	ь																							
1 0 1 0	1	0	1	0	10	end box	(2) separated graphics	*	□	:	□	J	Z	j	□	z	□	ü	Ų	Й	Э	й	э																							
1 0 1 1	1	0	1	1	11	start box	TWIST	+	□	;	□	K	é	k	□	ą	□	Ā	Ņ	К	Ш	к	ш																							
1 1 0 0	1	1	0	0	12	normal height	(2) black back-ground	,	□	<	□	L	ē	l	□	ų	□	ō	↓	Л	Э	л	э																							
1 1 0 1	1	1	0	1	13	double height	new back-ground	-	□	=	□	M	ž	m	□	ž	□	Ģ	Ģ	М	Щ	м	щ																							
1 1 1 0	1	1	1	0	14	SO	(1) hold graphics	.	□	>	□	N	č	n	□	į	□	Ü	°	Н	Ч	н	ч																							
1 1 1 1	1	1	1	1	15	SI	(1) release graphics	/	□	?	□	O	ū	o	□	□	□	ō	↓	О	Ы	о	ы																							

MBA648 - 1

---

## Integrated VIP and Teletext with Background Memory Controller (IVT1.1BMCX)

---

SAA5249

**Notes to Tables 12, 13, 14 and 15**

1. These control characters are reserved for compatibility with other data codes.
2. These control characters are presumed before each row begins.
3. Control characters shown in Columns 0 and 1 are normally displayed as spaces.
4. Characters may be referred to by column and row (for example 2/5 refers to %).
5. Black represents displayed colour. White represents background.
6. The SAA5249 national option characters are illustrated in Tables 16, 17, 18 and 19.
7. Characters 8/6, 8/7, 9/5, 9/6 and 9/7 are special characters for combining with character 8/5 (E, H and T codes only).
8. National option characters will be displayed according to the setting of control bits C12 to C14. These will be mapped into the basic code table into positions shown in Tables 16, 17, 18 and 19.
9. Columns 2a, 3a, 6a and 7a are displayed in graphics mode.

Integrated VIP and Teletext with Background  
Memory Controller (IVT1.1BMCX)

SAA5249

Table 16 SAA5249 basic character matrix; note 1

2/0		2/1	!	2/2	?	2/3	NC	2/4	NC	2/5	%	2/6	8	2/7	.
2/8	U	2/9	U	2/10	*	2/11	+	2/12	,	2/13		2/14	.	2/15	/
3/0	Q	3/1	I	3/2	N	3/3	M	3/4	V	3/5	W	3/6	R	3/7	Z
3/8	B	3/9	S	3/10	:	3/11	;	3/12	Y	3/13		3/14	A	3/15	E
4/0	NC	4/1	@	4/2	0	4/3	U	4/4	0	4/5	W	4/6	L	4/7	W
4/8	H	4/9	H	4/10	J	4/11	V	4/12	L	4/13	3	4/14	Z	4/15	0
5/0	E	5/1	B	5/2	R	5/3	U	5/4	T	5/5	Q	5/6	>	5/7	B
5/8	X	5/9	Y	5/10	N	5/11	NC	5/12	NC	5/13	NC	5/14	NC	5/15	NC
6/0	NC	6/1	@	6/2	9	6/3	U	6/4	0	6/5	0	6/6	4	6/7	0
6/8	U	6/9	I	6/10	J	6/11	Y	6/12	T	6/13	E	6/14	C	6/15	0
7/0	B	7/1	B	7/2	L	7/3	U	7/4	7	7/5	Q	7/6	>	7/7	3
7/8	X	7/9	Y	7/10	N	7/11	NC	7/12	NC	7/13	NC	7/14	NC	7/15	

Note

1. Where: NC = national option character position.

Integrated VIP and Teletext with Background  
Memory Controller (IVT1.1BMCX)

SAA5249

**Table 17** SAA5249P/E national option character set; note 1

LANGUAGE	PHCB <sup>(1)</sup>			CHARACTER POSITION (COLUMN / ROW)												
	C12	C13	C14	2 / 3	2 / 4	4 / 0	5 / 11	5 / 12	5 / 13	5 / 14	5 / 15	6 / 0	7 / 11	7 / 12	7 / 13	7 / 14
ENGLISH	0	0	0	£	\$	@	←	½	→	↑	#	—	¼		¾	÷
GERMAN	0	0	1	#	\$	§	Ä	Ö	Ü	^	_	°	ä	ö	ü	ß
SWEDISH	0	1	0	#	×	É	Ä	Ö	Å	Ü	_	é	ä	ö	å	ü
ITALIAN	0	1	1	£	\$	é	°	ç	→	↑	#	ù	à	ó	è	ì
FRENCH	1	0	0	é	ï	à	è	ë	ù	î	#	ê	â	ô	û	ç
SPANISH	1	0	1	ç	\$	í	á	é	í	ó	ú	ó	ü	ñ	è	à

MLB458

**Note**

- PHCB are the Page Header Control Bits. Other combinations default to English.

Integrated VIP and Teletext with Background  
Memory Controller (IVT1.1BMCX)

SAA5249

**Table 18** SAA5249P/H national option character set; note 1

LANGUAGE	PHCB <sup>(1)</sup>			CHARACTER POSITION (COLUMN / ROW)												
	C12	C13	C14	2/3	2/4	4/0	5/11	5/12	5/13	5/14	5/15	6/0	7/11	7/12	7/13	7/14
POLISH	0	0	0	#	ń	ą	z	ś	ł	ć	ó	ę	ź	ś	ż	ź
GERMAN	0	0	1	#	ß	š	ä	ö	ü	^	_	°	ä	ö	ü	ß
SWEDISH	0	1	0	#	å	é	ä	ö	å	ü	_	é	ä	ö	å	ü
SERBO-CROAT	1	0	1	#	½	č	ć	ž	đ	š	ě	č	ć	ž	đ	š
CZECHOSLOVAKIA	1	1	0	#	ů	č	ť	ž	ý	í	ř	é	á	ě	ú	š
RUMANIAN	1	1	1	#	å	ț	ă	ș	ă	î	ı	ț	ă	ș	ă	î

MLA966

**Note**

- PHCB are the Page Header Control Bits. Other combinations default to German. Only the above characters change with the PHCB. All other characters in the basic set are shown in Table 15.

Integrated VIP and Teletext with Background  
Memory Controller (IVT1.1BMCX)

SAA5249

Table 19 SAA5249P/R national option character set; note 1

LANGUAGE	PHCB <sup>(1)</sup>			CHARACTER POSITION (COLUMN / ROW)																																																																																																																																			
	C12	C13	C14	2 / 3	2 / 4	4 / 0	5 / 11	5 / 12	5 / 13	5 / 14	5 / 15	6 / 0	7 / 11	7 / 12	7 / 13	7 / 14																																																																																																																							
ESTONIAN	0	1	0	#	õ	š	ä	ö	ž	ü	õ	š	ä	ö	ž	ü																																																																																																																							
LETTISH / LITHUANIAN	0	1	1	#	\$	š	ē	ŗ	ž	č	ū	š	ŗ	ų	ž	į																																																																																																																							
RUSSIAN	1	0	0	<table border="1"> <thead> <tr> <th></th> <th>2</th> <th>3</th> <th>4</th> <th>5</th> <th>6</th> <th>7</th> </tr> </thead> <tbody> <tr> <td>0</td> <td>□</td> <td>О</td> <td>Ю</td> <td>П</td> <td>Ю</td> <td>п</td> </tr> <tr> <td>1</td> <td>!</td> <td>І</td> <td>А</td> <td>Я</td> <td>а</td> <td>я</td> </tr> <tr> <td>2</td> <td>”</td> <td>Ъ</td> <td>Р</td> <td>Ѡ</td> <td>р</td> <td></td> </tr> <tr> <td>3</td> <td>#</td> <td>З</td> <td>Ц</td> <td>С</td> <td>ц</td> <td>с</td> </tr> <tr> <td>4</td> <td>\$</td> <td>Ѹ</td> <td>Д</td> <td>Т</td> <td>д</td> <td>т</td> </tr> <tr> <td>5</td> <td>%</td> <td>Б</td> <td>Е</td> <td>У</td> <td>е</td> <td>у</td> </tr> <tr> <td>6</td> <td>ы</td> <td>Ѳ</td> <td>Ж</td> <td>Ѳ</td> <td>ж</td> <td></td> </tr> <tr> <td>7</td> <td>'</td> <td>Г</td> <td>В</td> <td>г</td> <td>в</td> <td></td> </tr> <tr> <td>8</td> <td>(</td> <td>Ѳ</td> <td>Х</td> <td>Ь</td> <td>х</td> <td>ь</td> </tr> <tr> <td>9</td> <td>)</td> <td>Ѳ</td> <td>И</td> <td>Ь</td> <td>и</td> <td>ь</td> </tr> <tr> <td>10</td> <td>ж</td> <td>:</td> <td>И</td> <td>З</td> <td>и</td> <td>э</td> </tr> <tr> <td>11</td> <td>+</td> <td>;</td> <td>К</td> <td>Ш</td> <td>к</td> <td>ш</td> </tr> <tr> <td>12</td> <td>,</td> <td>&lt;</td> <td>Л</td> <td>Э</td> <td>л</td> <td>э</td> </tr> <tr> <td>13</td> <td>-</td> <td>=</td> <td>М</td> <td>Щ</td> <td>м</td> <td>щ</td> </tr> <tr> <td>14</td> <td>.</td> <td>&gt;</td> <td>Н</td> <td>Ч</td> <td>н</td> <td>ч</td> </tr> <tr> <td>15</td> <td>/</td> <td>?</td> <td>О</td> <td>Ы</td> <td>о</td> <td>■</td> </tr> </tbody> </table>														2	3	4	5	6	7	0	□	О	Ю	П	Ю	п	1	!	І	А	Я	а	я	2	”	Ъ	Р	Ѡ	р		3	#	З	Ц	С	ц	с	4	\$	Ѹ	Д	Т	д	т	5	%	Б	Е	У	е	у	6	ы	Ѳ	Ж	Ѳ	ж		7	'	Г	В	г	в		8	(	Ѳ	Х	Ь	х	ь	9	)	Ѳ	И	Ь	и	ь	10	ж	:	И	З	и	э	11	+	;	К	Ш	к	ш	12	,	<	Л	Э	л	э	13	-	=	М	Щ	м	щ	14	.	>	Н	Ч	н	ч	15	/	?	О	Ы	о	■
	2	3	4	5	6	7																																																																																																																																	
0	□	О	Ю	П	Ю	п																																																																																																																																	
1	!	І	А	Я	а	я																																																																																																																																	
2	”	Ъ	Р	Ѡ	р																																																																																																																																		
3	#	З	Ц	С	ц	с																																																																																																																																	
4	\$	Ѹ	Д	Т	д	т																																																																																																																																	
5	%	Б	Е	У	е	у																																																																																																																																	
6	ы	Ѳ	Ж	Ѳ	ж																																																																																																																																		
7	'	Г	В	г	в																																																																																																																																		
8	(	Ѳ	Х	Ь	х	ь																																																																																																																																	
9	)	Ѳ	И	Ь	и	ь																																																																																																																																	
10	ж	:	И	З	и	э																																																																																																																																	
11	+	;	К	Ш	к	ш																																																																																																																																	
12	,	<	Л	Э	л	э																																																																																																																																	
13	-	=	М	Щ	м	щ																																																																																																																																	
14	.	>	Н	Ч	н	ч																																																																																																																																	
15	/	?	О	Ы	о	■																																																																																																																																	

MEA597

Note

1. PHCB are the Page Header Control Bits. Other combinations default to Estonian.

Integrated VIP and Teletext with Background  
Memory Controller (IVT1.1BMCX)

SAA5249

PACKAGE OUTLINES

DIP48: plastic dual in-line package; 48 leads (600 mil)

SOT240-1

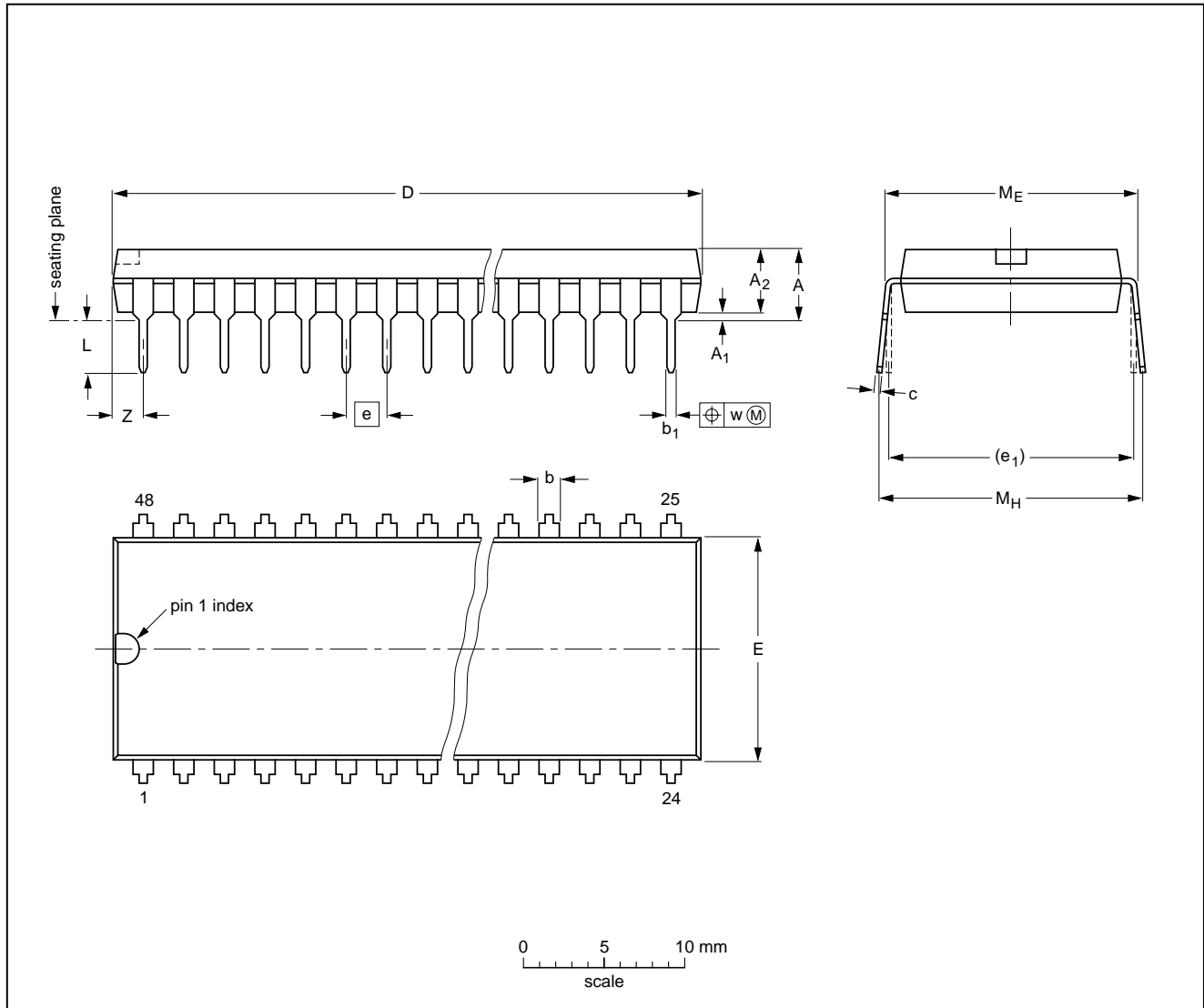

DIMENSIONS (inch dimensions are derived from the original mm dimensions)

UNIT	A max.	A <sub>1</sub> min.	A <sub>2</sub> max.	b	b <sub>1</sub>	c	D <sup>(1)</sup>	E <sup>(1)</sup>	e	e <sub>1</sub>	L	M <sub>E</sub>	M <sub>H</sub>	w	Z <sup>(1)</sup> max.
mm	4.9	0.36	4.06	1.4 1.14	0.53 0.38	0.36 0.23	62.60 61.60	14.22 13.56	2.54	15.24	3.90 3.05	15.88 15.24	18.46 15.24	0.254	2.1
inches	0.19	0.014	0.16	0.055 0.045	0.021 0.015	0.014 0.009	2.46 2.42	0.56 0.53	0.10	0.60	0.15 0.12	0.63 0.60	0.73 0.60	0.01	0.083

Note  
1. Plastic or metal protrusions of 0.25 mm maximum per side are not included.

OUTLINE VERSION	REFERENCES				EUROPEAN PROJECTION	ISSUE DATE
	IEC	JEDEC	EIAJ			
SOT240-1						92-11-17 95-01-25

Integrated VIP and Teletext with Background  
Memory Controller (IVT1.1BMCX)

SAA5249

**QFP64: plastic quad flat package;**  
**64 leads (lead length 1.95 mm); body 14 x 20 x 2.7 mm; high stand-off height**

**SOT319-1**

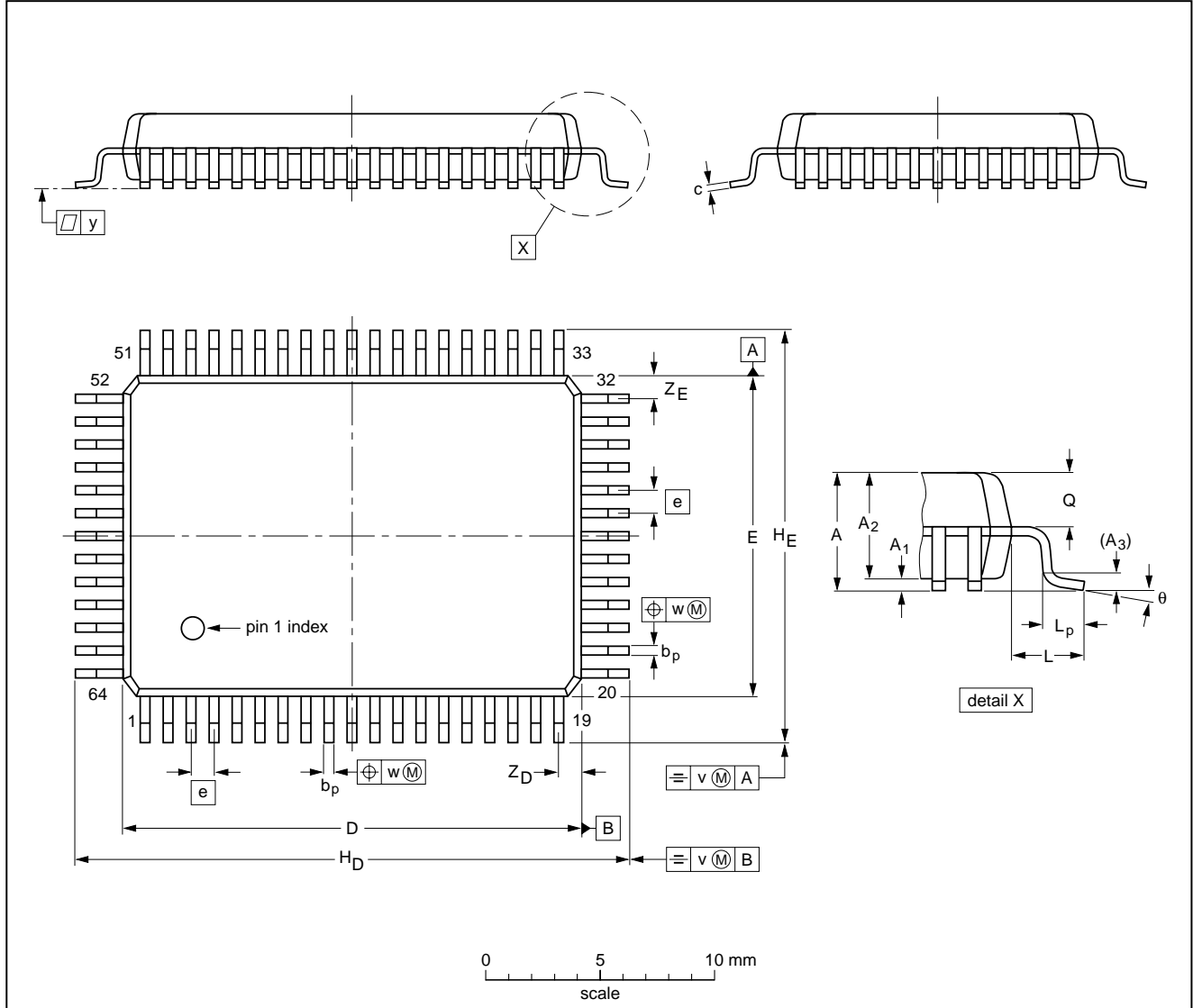

**DIMENSIONS (mm are the original dimensions)**

UNIT	A max.	A <sub>1</sub>	A <sub>2</sub>	A <sub>3</sub>	b <sub>p</sub>	c	D <sup>(1)</sup>	E <sup>(1)</sup>	e	H <sub>D</sub>	H <sub>E</sub>	L	L <sub>p</sub>	Q	v	w	y	Z <sub>D</sub> <sup>(1)</sup>	Z <sub>E</sub> <sup>(1)</sup>	θ
mm	3.3	0.36 0.10	2.87 2.57	0.25	0.50 0.35	0.25 0.13	20.1 19.9	14.1 13.9	1	24.2 23.6	18.2 17.6	1.95	1.0 0.6	1.43 1.23	0.2	0.2	0.1	1.2 0.8	1.2 0.8	7° 0°

**Note**

1. Plastic or metal protrusions of 0.25 mm maximum per side are not included.

OUTLINE VERSION	REFERENCES			EUROPEAN PROJECTION	ISSUE DATE
	IEC	JEDEC	EIAJ		
SOT319-1					92-11-17 95-02-04



## Integrated VIP and Teletext with Background Memory Controller (IVT1.1BMCX)

SAA5249

### SOLDERING

#### Introduction

There is no soldering method that is ideal for all IC packages. Wave soldering is often preferred when through-hole and surface mounted components are mixed on one printed-circuit board. However, wave soldering is not always suitable for surface mounted ICs, or for printed-circuits with high population densities. In these situations reflow soldering is often used.

This text gives a very brief insight to a complex technology. A more in-depth account of soldering ICs can be found in our *"IC Package Databook"* (order code 9398 652 90011).

#### DIP

##### SOLDERING BY DIPPING OR BY WAVE

The maximum permissible temperature of the solder is 260 °C; solder at this temperature must not be in contact with the joint for more than 5 seconds. The total contact time of successive solder waves must not exceed 5 seconds.

The device may be mounted up to the seating plane, but the temperature of the plastic body must not exceed the specified maximum storage temperature ( $T_{stg\ max}$ ). If the printed-circuit board has been pre-heated, forced cooling may be necessary immediately after soldering to keep the temperature within the permissible limit.

##### REPAIRING SOLDERED JOINTS

Apply a low voltage soldering iron (less than 24 V) to the lead(s) of the package, below the seating plane or not more than 2 mm above it. If the temperature of the soldering iron bit is less than 300 °C it may remain in contact for up to 10 seconds. If the bit temperature is between 300 and 400 °C, contact may be up to 5 seconds.

#### QFP

##### REFLOW SOLDERING

Reflow soldering techniques are suitable for all QFP packages.

The choice of heating method may be influenced by larger plastic QFP packages (44 leads, or more). If infrared or vapour phase heating is used and the large packages are not absolutely dry (less than 0.1% moisture content by weight), vaporization of the small amount of moisture in them can cause cracking of the plastic body. For more information, refer to the Drypack chapter in our *"Quality Reference Handbook"* (order code 9397 750 00192).

Reflow soldering requires solder paste (a suspension of fine solder particles, flux and binding agent) to be applied to the printed-circuit board by screen printing, stencilling or pressure-syringe dispensing before package placement.

Several techniques exist for reflowing; for example, thermal conduction by heated belt. Dwell times vary from 50 to 300 seconds depending on heating method. Typical reflow temperatures range from 215 to 250 °C.

Preheating is necessary to dry the paste and evaporate the binding agent. Preheat for 45 minutes at 45 °C.

##### WAVE SOLDERING

Wave soldering is **not** recommended for QFP packages. This is because of the likelihood of solder bridging due to closely-spaced leads and the possibility of incomplete solder penetration in multi-lead devices.

#### If wave soldering cannot be avoided, the following conditions must be observed:

- **A double-wave (a turbulent wave with high upward pressure followed by a smooth laminar wave) soldering technique should be used.**
- **The footprint must be at an angle of 45° to the board direction and must incorporate solder thieves downstream and at the side corners.**

**Even with these conditions, do not consider wave soldering the following packages: QFP52 (SOT379-1), QFP100 (SOT317-1), QFP100 (SOT317-2), QFP100 (SOT382-1) or QFP160 (SOT322-1).**

During placement and before soldering, the package must be fixed with a droplet of adhesive. The adhesive can be applied by screen printing, pin transfer or syringe dispensing. The package can be soldered after the adhesive is cured. Maximum permissible solder temperature is 260 °C, and maximum duration of package immersion in solder is 10 seconds, if cooled to less than 150 °C within 6 seconds. Typical dwell time is 4 seconds at 250 °C.

A mildly-activated flux will eliminate the need for removal of corrosive residues in most applications.

##### REPAIRING SOLDERED JOINTS

Fix the component by first soldering two diagonally-opposite end leads. Use only a low voltage soldering iron (less than 24 V) applied to the flat part of the lead. Contact time must be limited to 10 seconds at up to 300 °C. When using a dedicated tool, all other leads can be soldered in one operation within 2 to 5 seconds between 270 and 320 °C.

# Integrated VIP and Teletext with Background Memory Controller (IVT1.1BMCX)

SAA5249

## DEFINITIONS

<b>Data sheet status</b>	
Objective specification	This data sheet contains target or goal specifications for product development.
Preliminary specification	This data sheet contains preliminary data; supplementary data may be published later.
Product specification	This data sheet contains final product specifications.
<b>Limiting values</b>	
Limiting values given are in accordance with the Absolute Maximum Rating System (IEC 134). Stress above one or more of the limiting values may cause permanent damage to the device. These are stress ratings only and operation of the device at these or at any other conditions above those given in the Characteristics sections of the specification is not implied. Exposure to limiting values for extended periods may affect device reliability.	
<b>Application information</b>	
Where application information is given, it is advisory and does not form part of the specification.	

## LIFE SUPPORT APPLICATIONS

These products are not designed for use in life support appliances, devices, or systems where malfunction of these products can reasonably be expected to result in personal injury. Philips customers using or selling these products for use in such applications do so at their own risk and agree to fully indemnify Philips for any damages resulting from such improper use or sale.

## PURCHASE OF PHILIPS I<sup>2</sup>C COMPONENTS



Purchase of Philips I<sup>2</sup>C components conveys a license under the Philips' I<sup>2</sup>C patent to use the components in the I<sup>2</sup>C system provided the system conforms to the I<sup>2</sup>C specification defined by Philips. This specification can be ordered using the code 9398 393 40011.

---

Integrated VIP and Teletext with Background  
Memory Controller (IVT1.1BMCX)

---

SAA5249

NOTES

# Philips Semiconductors – a worldwide company

**Argentina:** see South America

**Australia:** 34 Waterloo Road, NORTH RYDE, NSW 2113,  
Tel. +61 2 9805 4455, Fax. +61 2 9805 4466

**Austria:** Computerstr. 6, A-1101 WIEN, P.O. Box 213,  
Tel. +43 1 60 101, Fax. +43 1 60 101 1210

**Belarus:** Hotel Minsk Business Center, Bld. 3, r. 1211, Volodarski Str. 6,  
220050 MINSK, Tel. +375 172 200 733, Fax. +375 172 200 773

**Belgium:** see The Netherlands

**Brazil:** see South America

**Bulgaria:** Philips Bulgaria Ltd., Energoproject, 15th floor,  
51 James Bourchier Blvd., 1407 SOFIA,  
Tel. +359 2 689 211, Fax. +359 2 689 102

**Canada:** PHILIPS SEMICONDUCTORS/COMPONENTS,  
Tel. +1 800 234 7381

**China/Hong Kong:** 501 Hong Kong Industrial Technology Centre,  
72 Tat Chee Avenue, Kowloon Tong, HONG KONG,  
Tel. +852 2319 7888, Fax. +852 2319 7700

**Colombia:** see South America

**Czech Republic:** see Austria

**Denmark:** Prags Boulevard 80, PB 1919, DK-2300 COPENHAGEN S,  
Tel. +45 32 88 2636, Fax. +45 31 57 1949

**Finland:** Sinikalliontie 3, FIN-02630 ESPOO,  
Tel. +358 9 615800, Fax. +358 9 61580/xxx

**France:** 4 Rue du Port-aux-Vins, BP317, 92156 SURESNES Cedex,  
Tel. +33 1 40 99 6161, Fax. +33 1 40 99 6427

**Germany:** Hammerbrookstraße 69, D-20097 HAMBURG,  
Tel. +49 40 23 53 60, Fax. +49 40 23 536 300

**Greece:** No. 15, 25th March Street, GR 17778 TAVROS/ATHENS,  
Tel. +30 1 4894 339/239, Fax. +30 1 4814 240

**Hungary:** see Austria

**India:** Philips INDIA Ltd, Shivsagar Estate, A Block, Dr. Annie Besant Rd.  
Worli, MUMBAI 400 018, Tel. +91 22 4938 541, Fax. +91 22 4938 722

**Indonesia:** see Singapore

**Ireland:** Newstead, Clonskeagh, DUBLIN 14,  
Tel. +353 1 7640 000, Fax. +353 1 7640 200

**Israel:** RAPAC Electronics, 7 Kehilat Saloniki St, TEL AVIV 61180,  
Tel. +972 3 645 0444, Fax. +972 3 649 1007

**Italy:** PHILIPS SEMICONDUCTORS, Piazza IV Novembre 3,  
20124 MILANO, Tel. +39 2 6752 2531, Fax. +39 2 6752 2557

**Japan:** Philips Bldg 13-37, Kohnan 2-chome, Minato-ku, TOKYO 108,  
Tel. +81 3 3740 5130, Fax. +81 3 3740 5077

**Korea:** Philips House, 260-199 Itaewon-dong, Yongsan-ku, SEOUL,  
Tel. +82 2 709 1412, Fax. +82 2 709 1415

**Malaysia:** No. 76 Jalan Universiti, 46200 PETALING JAYA, SELANGOR,  
Tel. +60 3 750 5214, Fax. +60 3 757 4880

**Mexico:** 5900 Gateway East, Suite 200, EL PASO, TEXAS 79905,  
Tel. +9-5 800 234 7381

**Middle East:** see Italy

**Netherlands:** Postbus 90050, 5600 PB EINDHOVEN, Bldg. VB,  
Tel. +31 40 27 82785, Fax. +31 40 27 88399

**New Zealand:** 2 Wagener Place, C.P.O. Box 1041, AUCKLAND,  
Tel. +64 9 849 4160, Fax. +64 9 849 7811

**Norway:** Box 1, Manglerud 0612, OSLO,  
Tel. +47 22 74 8000, Fax. +47 22 74 8341

**Philippines:** Philips Semiconductors Philippines Inc.,  
106 Valero St. Salcedo Village, P.O. Box 2108 MCC, MAKATI,  
Metro MANILA, Tel. +63 2 816 6380, Fax. +63 2 817 3474

**Poland:** Ul. Lukiska 10, PL 04-123 WARSZAWA,  
Tel. +48 22 612 2831, Fax. +48 22 612 2327

**Portugal:** see Spain

**Romania:** see Italy

**Russia:** Philips Russia, Ul. Usatcheva 35A, 119048 MOSCOW,  
Tel. +7 095 247 9145, Fax. +7 095 247 9144

**Singapore:** Lorong 1, Toa Payoh, SINGAPORE 1231,  
Tel. +65 350 2538, Fax. +65 251 6500

**Slovakia:** see Austria

**Slovenia:** see Italy

**South Africa:** S.A. PHILIPS Pty Ltd., 195-215 Main Road Martindale,  
2092 JOHANNESBURG, P.O. Box 7430 Johannesburg 2000,  
Tel. +27 11 470 5911, Fax. +27 11 470 5494

**South America:** Rua do Rocio 220, 5th floor, Suite 51,  
04552-903 São Paulo, SÃO PAULO - SP, Brazil,  
Tel. +55 11 821 2333, Fax. +55 11 829 1849

**Spain:** Balmes 22, 08007 BARCELONA,  
Tel. +34 3 301 6312, Fax. +34 3 301 4107

**Sweden:** Kottbygatan 7, Akalla, S-16485 STOCKHOLM,  
Tel. +46 8 632 2000, Fax. +46 8 632 2745

**Switzerland:** Allmendstrasse 140, CH-8027 ZÜRICH,  
Tel. +41 1 488 2686, Fax. +41 1 481 7730

**Taiwan:** PHILIPS TAIWAN Ltd., 23-30F, 66,  
Chung Hsiao West Road, Sec. 1, P.O. Box 22978,  
TAIPEI 100, Tel. +886 2 382 4443, Fax. +886 2 382 4444

**Thailand:** PHILIPS ELECTRONICS (THAILAND) Ltd.,  
209/2 Sanpavuth-Bangna Road Prakanong, BANGKOK 10260,  
Tel. +66 2 745 4090, Fax. +66 2 398 0793

**Turkey:** Talatpasa Cad. No. 5, 80640 GÜLTEPE/ISTANBUL,  
Tel. +90 212 279 2770, Fax. +90 212 282 6707

**Ukraine:** PHILIPS UKRAINE, 4 Patrice Lumumba str., Building B, Floor 7,  
252042 KIEV, Tel. +380 44 264 2776, Fax. +380 44 268 0461

**United Kingdom:** Philips Semiconductors Ltd., 276 Bath Road, Hayes,  
MIDDLESEX UB3 5BX, Tel. +44 181 730 5000, Fax. +44 181 754 8421

**United States:** 811 East Arques Avenue, SUNNYVALE, CA 94088-3409,  
Tel. +1 800 234 7381

**Uruguay:** see South America

**Vietnam:** see Singapore

**Yugoslavia:** PHILIPS, Trg N. Pasica 5/v, 11000 BEOGRAD,  
Tel. +381 11 625 344, Fax. +381 11 635 777

**For all other countries apply to:** Philips Semiconductors, Marketing & Sales Communications,  
Building BE-p, P.O. Box 218, 5600 MD EINDHOVEN, The Netherlands, Fax. +31 40 27 24825

**Internet:** <http://www.semiconductors.philips.com>

© Philips Electronics N.V. 1996

SCA52

All rights are reserved. Reproduction in whole or in part is prohibited without the prior written consent of the copyright owner.

The information presented in this document does not form part of any quotation or contract, is believed to be accurate and reliable and may be changed without notice. No liability will be accepted by the publisher for any consequence of its use. Publication thereof does not convey nor imply any license under patent- or other industrial or intellectual property rights.

Printed in The Netherlands

537021/50/02/pp44

Date of release: 1996 Nov 07

Document order number: 9397 750 01014

*Let's make things better.*

**Philips**  
Semiconductors



**PHILIPS**